



INSTALLATION MANUAL

**Indoor unit for air to water heat pump and
sanitary warm water tank for air to water
heat pump system**

**EKHBH007A
EKHBX007A**

**EKSWW150V3
EKSWW200V3
EKSWW300V3**

**EKSWW200Z2
EKSWW300Z2**

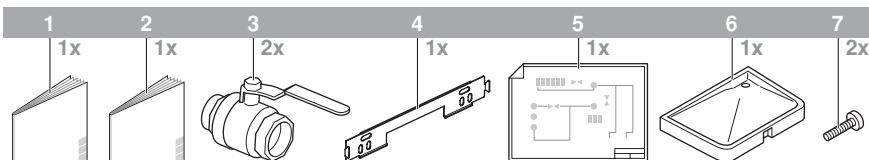

1

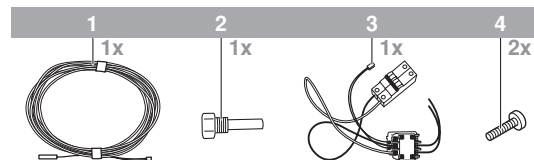

2

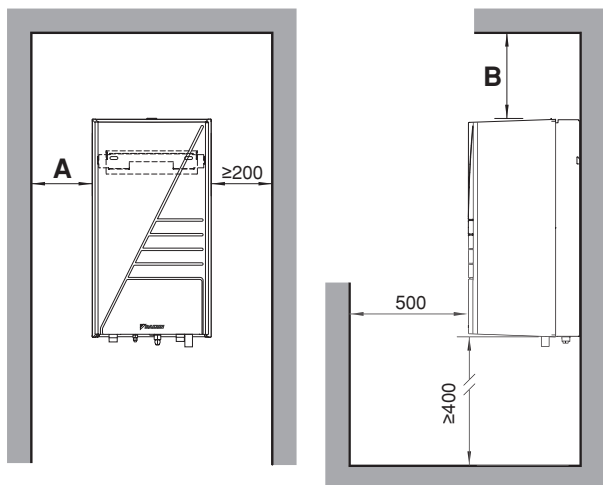

3 EKHBX

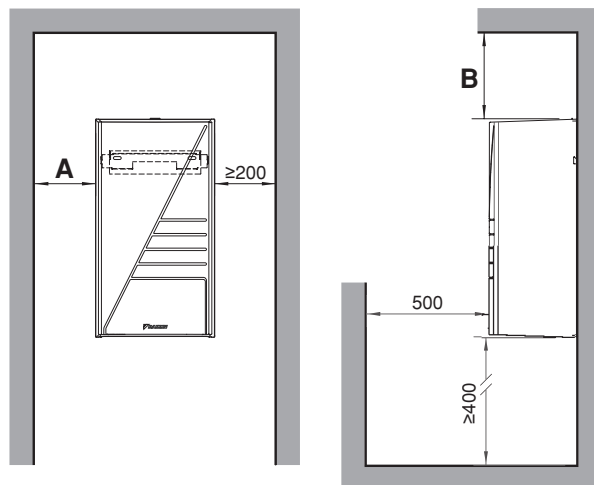

4 EKHBH

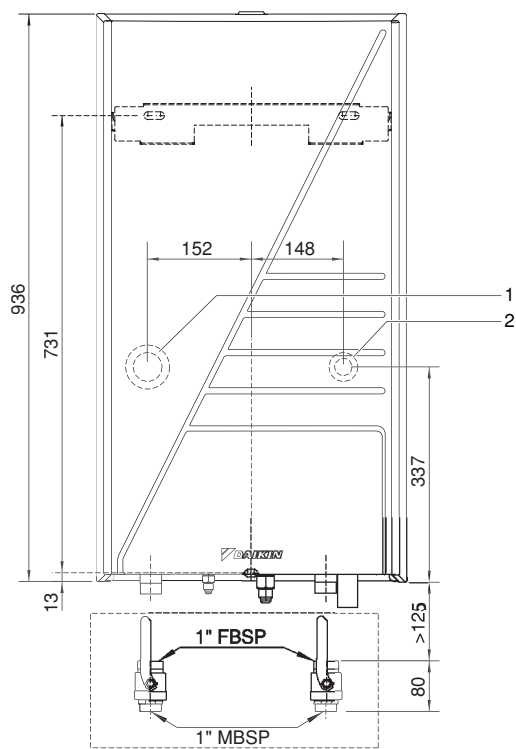

5 EKHBX

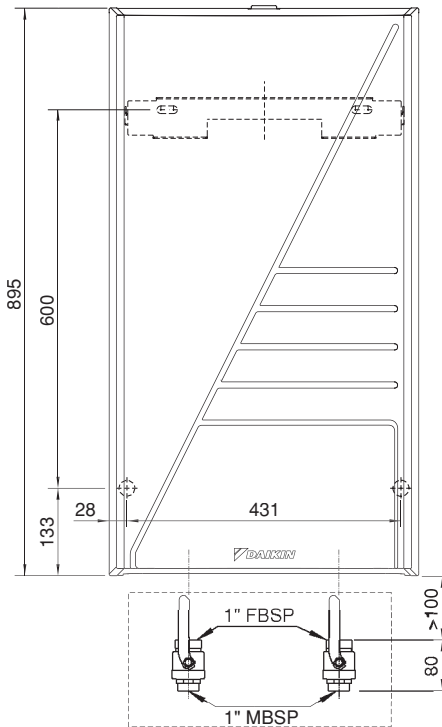

6 EKHBH

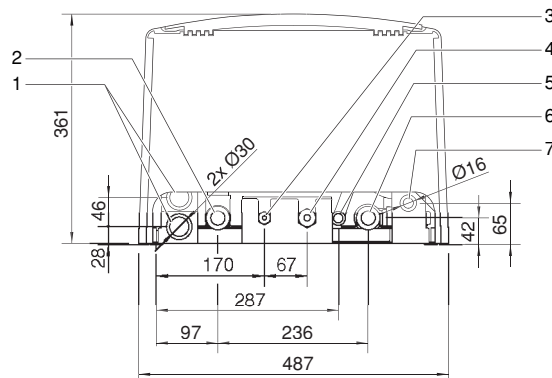
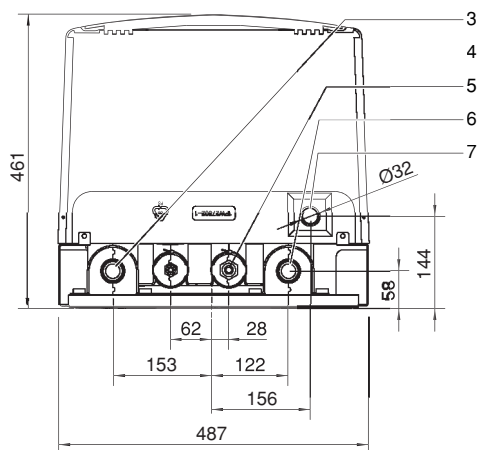

CONTENTS

	Page
Introduction	2
General information.....	2
Scope of this manual.....	2
Model identification	2
Accessories.....	2
Accessories supplied with the indoor unit	2
Accessories supplied with the sanitary water tank (optional).....	2
Typical application examples.....	3
Application 1	3
Application 2	3
Application 3	4
Application 4	4
Overview of the indoor unit	5
Opening the indoor unit.....	5
Main components.....	6
Switch box main components	7
Functional diagram.....	7
Installation of the indoor unit	8
Selecting an installation location	8
Dimensions and service space	8
Inspecting, handling and unpacking the unit	8
Mounting the indoor unit	9
Installation of the drain pan (only for EKHBX models)	9
Refrigerant pipework.....	10
Water pipework	10
Charging water.....	11
Piping insulation	11
Field wiring.....	11
Sanitary water tank (optional)	15
Main components.....	15
Outlook diagram.....	15
Installation guidelines.....	16
Installing the sanitary water tank.....	16
Connecting the water circuits	16
Field wiring.....	16
Start-up and configuration.....	17
DIP switch settings overview.....	17
Room thermostat installation configuration.....	17
Pump operation configuration	18
Sanitary water tank installation configuration.....	18
Pre-operation checks	18
Powering up the indoor unit.....	19
Setting the pump speed	19
Field settings.....	19
Test run and final check	24
Test run operation	24
Final check.....	24
Maintenance	24
Troubleshooting.....	25
General guidelines	25
General symptoms	25
Error codes	26
Technical specifications	27
General	27
Electrical specifications	27
Sanitary water tank specifications (optional).....	27



READ THESE INSTRUCTIONS CAREFULLY BEFORE INSTALLATION. KEEP THIS MANUAL IN A HANDY PLACE FOR FUTURE REFERENCE.

IMPROPER INSTALLATION OR ATTACHMENT OF EQUIPMENT OR ACCESSORIES COULD RESULT IN ELECTRIC SHOCK, SHORT-CIRCUIT, LEAKS, FIRE OR OTHER DAMAGE TO THE EQUIPMENT. BE SURE ONLY TO USE ACCESSORIES MADE BY DAIKIN WHICH ARE SPECIFICALLY DESIGNED FOR USE WITH THE EQUIPMENT AND HAVE THEM INSTALLED BY A PROFESSIONAL.

IF UNSURE OF INSTALLATION PROCEDURES OR USE, ALWAYS CONTACT YOUR DAIKIN DEALER FOR ADVICE AND INFORMATION.

THE UNIT DESCRIBED IN THIS MANUAL IS DESIGNED FOR INDOOR INSTALLATION ONLY AND FOR AMBIENT TEMPERATURES RANGING 0°C~35°C.

INTRODUCTION

General information

Thank you for purchasing this **altherma[®] by DAIKIN** indoor unit.

The **altherma[®] by DAIKIN** indoor unit is the indoor part of the reversible air to water Daikin ERYQ heat pumps. These units are designed for wall mounted indoor installation and used for both heating and cooling applications. The units can be combined with Daikin fan coil units, floor heating applications, low temperature radiators and sanitary water heating applications.

Heating/cooling units and heating only units

The **altherma[®] by DAIKIN** indoor unit range consists of two main versions: a heating/cooling (EKHBX) version and a heating only (EKHBH) version.

Both versions are delivered with an integrated backup heater for additional heating capacity during cold outdoor temperatures. The backup heater also serves as a backup in case of malfunctioning of the outdoor unit. The backup heater models are available for a heating capacity of 3, 6 and 9 kW, and – depending on the heating capacity – for three different power supply specifications.

Indoor unit model	Backup heater capacity	Backup heater nominal voltage
EKHB*007A3V3	3 kW	1 x 230 V
EKHB*007A6V3	6 kW	1 x 230 V
EKHB*007A6W1	6 kW	3 x 400 V + N
EKHB*007A9W1	9 kW	3 x 400 V + N
EKHB*007A6T1	6 kW	3 x 230 V
EKHB*007A9T1	9 kW	3 x 230 V

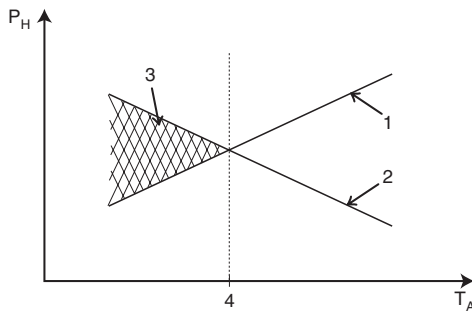

- 1 Heat pump capacity
- 2 Required heating capacity (site dependent)
- 3 Additional heating capacity provided by the backup heater
- 4 Equilibrium temperature (can be set through the user interface, refer to "Field settings" on page 19)

T_A Ambient (outdoor) temperature

P_H Heating capacity

Sanitary water tank option

An optional EKSWW sanitary water tank with integrated 3kW electrical booster heater can be connected to the indoor unit. The sanitary water tank is available in three sizes: 150, 200 and 300 litre. All models can be floor mounted, while the 150 litre model can be wall mounted as well via option kit EKWSWW150.

Scope of this manual

This installation manual describes the procedures for unpacking, installing and connecting all EKHBH/X indoor unit models and the optional EKSWW sanitary water tanks.

- NOTE**
- Installation of the ERYQ heat pump outdoor is described in the outdoor unit installation manual.
 - Operation of the indoor unit is described in the indoor unit operation manual.

Model identification

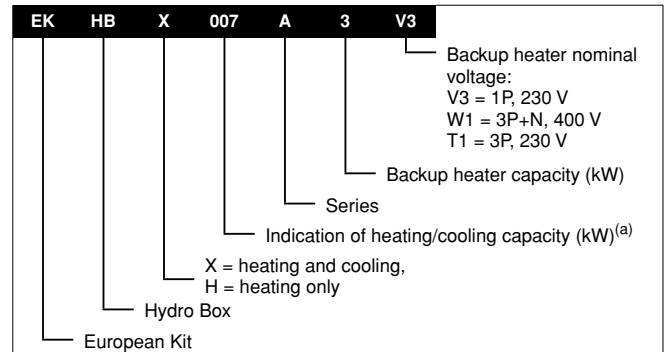

(a) For exact values, refer to "Technical specifications" on page 27.

ACCESSORIES

Accessories supplied with the indoor unit

See figure 1

- 1 Installation manual
- 2 Operation manual
- 3 Shut-off valve
- 4 Wall mounting bracket
- 5 Wiring diagram sticker (inside indoor unit cover)
- 6 Drain pan and fixing screws (only for EKHBX models)
- 7 Indoor unit cover fixing screw + nylon washer

Accessories supplied with the sanitary water tank (optional)

See figure 2

- 1 Thermistor + connection wire (12 m)
- 2 Thermistor socket
- 3 Prewired contactor and circuit breaker assembly
- 4 Contactor fixing screw

TYPICAL APPLICATION EXAMPLES



When the **altherma**® by **DAIKIN** system is used in series with another heat source (e.g. gas boiler), it shall be made sure that the return water temperature to the heat exchanger does not exceed 55°C. Daikin shall not be held liable for any damage resulting from not observing this rule.

The application examples given below are for illustration purposes only.

Application 1

Space heating only application with a room thermostat connected to the indoor unit.

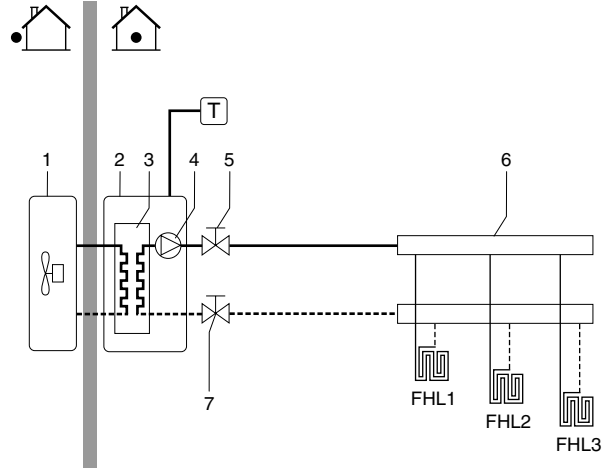

- | | | | |
|---|----------------|---------|-----------------------------------|
| 1 | Outdoor unit | 6 | Collector (field supply) |
| 2 | Indoor unit | 7 | Shut-off valve |
| 3 | Heat exchanger | FHL1..3 | Floor heating loop (field supply) |
| 4 | Pump | T | Room thermostat (field supply) |
| 5 | Shut-off valve | | |

Pump operation and space heating

When a room thermostat (T) is connected to the indoor unit, the pump (4) will operate when there is a heating request from the room thermostat, and the outdoor unit will start operating to achieve the target leaving water temperature as set on the user interface.

When the room temperature is above the thermostat set point, the outdoor unit and pump will stop operating.



Make sure to connect the thermostat wires to the correct terminals (see "Connection of the thermostat cable" on page 14) and to configure the DIP switch toggle switches correctly (see "Room thermostat installation configuration" on page 17).

Application 2

Space heating only application without room thermostat connected to the indoor unit. The temperature in each room is controlled by a valve on each water circuit. Sanitary warm water is provided through the sanitary water tank which is connected to the indoor unit.

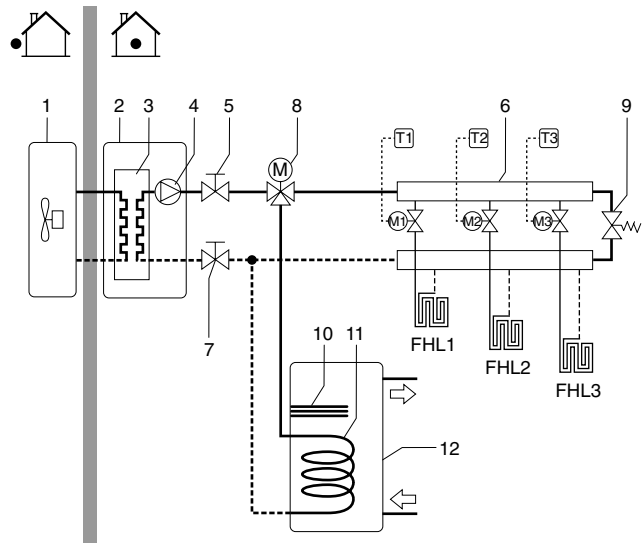

- | | | | |
|---|--------------------------------------|---------|--|
| 1 | Outdoor unit | 10 | Booster heater |
| 2 | Indoor unit | 11 | Heat exchanger coil |
| 3 | Heat exchanger | 12 | Sanitary water tank |
| 4 | Pump | FHL1..3 | Floor heating loop (field supply) |
| 5 | Shut-off valve | T1..3 | Individual room thermostat (field supply) |
| 6 | Collector (field supply) | M1..3 | Individual motorised valve to control loop FHL1 (field supply) |
| 7 | Shut-off valve | | |
| 8 | Motorised 3-way valve (field supply) | | |
| 9 | By-pass valve (field supply) | | |

Pump operation

With no thermostat connected to the indoor unit (2), the pump (4) can be configured to operate either as long as the indoor unit is on, or until the required water temperature is reached.

NOTE



Details on pump configuration can be found under "Pump operation configuration" on page 18.

Space heating

The outdoor unit (1) will operate to achieve the target leaving water temperature as set on the user interface.



When circulation in each space heating loop (FHL1..3) is controlled by remotely controlled valves (M1..3), it is important to provide a by-pass valve (9) to avoid the flow switch safety device from being activated.

The by-pass valve should be selected as such that at all time the minimum water flow as mentioned under "Water pipework" on page 10 is guaranteed.

Sanitary heating

When sanitary heating mode is enabled (either manually by the user, or automatically through a schedule timer) the target sanitary water temperature will be achieved by a combination of the heat exchanger coil and the electrical booster heater.

When the sanitary water temperature is below the user configured set point, the 3-way valve will be activated to heat the sanitary water by means of the heat pump. In case of large sanitary water demand or a high sanitary water temperature setting, the booster heater (10) can provide auxiliary heating.



Make sure to fit the 3-way valve (8) correctly: when the 3-way valve is idle (not activated), the space heating circuit (i.e. floor heating loops) should be selected.



NOTE The indoor unit can be configured so that at low outdoor temperatures the sanitary water is exclusively heated by the booster heater. This assures that the full capacity of the heat pump is available for space heating.

Details on sanitary water tank configuration for low outdoor temperatures can be found under "[Field settings](#)" on page 19, field settings [5-02] to [5-04].

Application 3

Space cooling and heating application with a **room thermostat suitable for cooling/heating changeover** connected to the indoor unit. Heating is provided through floor heating loops and fan coil units. Cooling is provided through the fan coil units only. Sanitary warm water is provided through the sanitary water tank which is connected to the indoor unit.

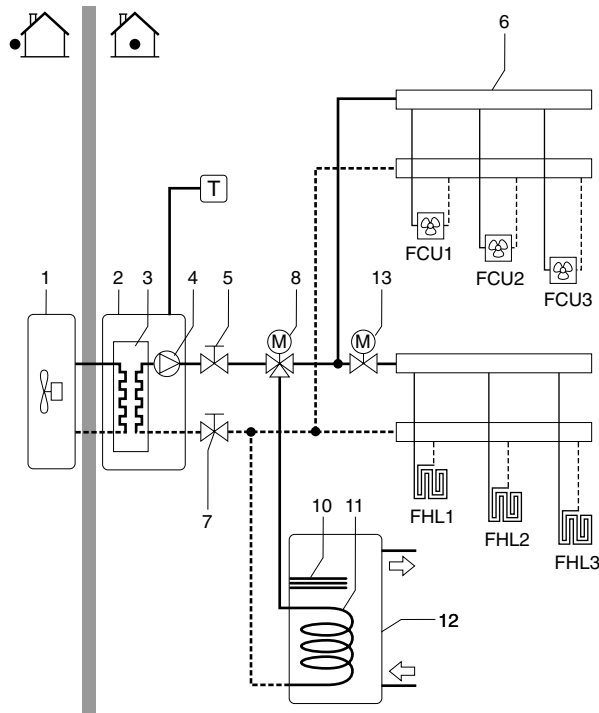

1	Outdoor unit	10	Booster heater
2	Indoor unit	11	Heat exchanger coil
3	Heat exchanger	12	Sanitary water tank
4	Pump	13	Motorised 2-way valve (field supply)
5	Shut-off valve		
6	Collector (field supply)	FCU1..3	Fan coil unit (field supply)
7	Shut-off valve	FHL1..3	Floor heating loop (field supply)
8	Motorised 3-way valve (field supply)	T	Room thermostat with cooling/heating switch (field supply)

Pump operation and space heating and cooling

According to the season, the customer will select cooling or heating on the room thermostat (T). This selection is not possible by operating the user interface.

When space cooling/heating is requested by the room thermostat (T), the pump will start operating and the indoor unit (2) will switch to "cooling mode"/"heating mode". The outdoor unit (1) will start operating to achieve the target leaving cold/hot water temperature.

In case of cooling mode, the motorised 2-way valve (13) will close as to prevent cold water running through the floor heating loops (FHL).



Make sure to connect the thermostat wires to the correct terminals (see "[Connection of the thermostat cable](#)" on page 14) and to configure the DIP switch toggle switches correctly (see "[Room thermostat installation configuration](#)" on page 17).



Wiring of the 2-way valve (13) is different for a NC (normal closed) valve and a NO (normal open) valve! Make sure to connect to the correct terminal numbers as detailed on the wiring diagram.

The ON/OFF setting of the heating/cooling operation is done by the room thermostat and cannot be done by the user interface on the indoor unit.

Sanitary heating

Sanitary water heating is as described under "[Application 2](#)" on page 3.

Application 4

Space cooling and heating application **without a room thermostat connected to the indoor unit**, but with a heating only room thermostat controlling the floor heating and a cooling/heating thermostat controlling the fan coil units. Heating is provided through floor heating loops and fan coil units. Cooling is provided through the fan coil units only.

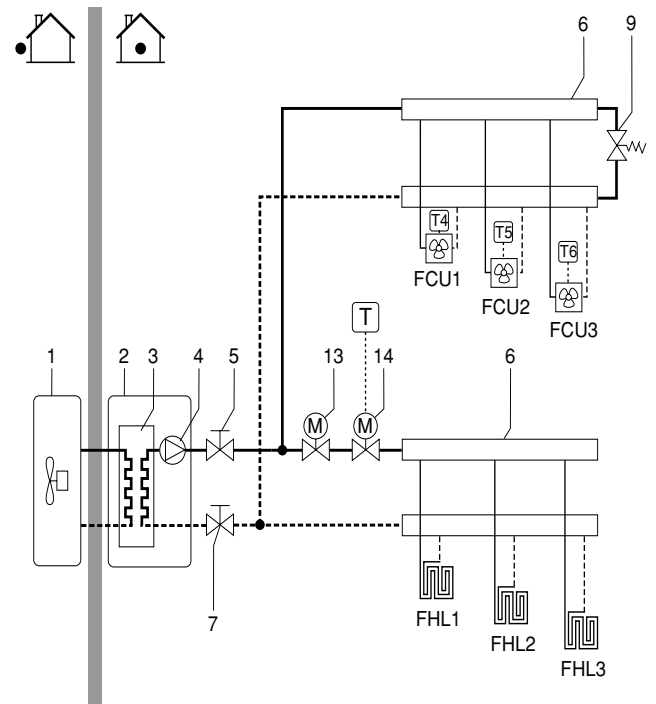

1	Outdoor unit	14	Motorised 2-way valve for activation of the room thermostat (field supply)
2	Indoor unit		
3	Heat exchanger		
4	Pump	FCU1..3	Fan coil unit with thermostat (field supply)
5	Shut-off valve		
6	Collector (field supply)	FHL1..3	Floor heating loop (field supply)
7	Shut-off valve		
9	By-pass valve (field supply)	T	Heating only room thermostat (field supply)
13	Motorised 2-way valve to shut off the floor heating loops during cooling operation (field supply)	T4..6	Individual room thermostat for fan coil heated/cooled room (field supply)

Pump operation

With no thermostat connected to the indoor unit (2), the pump (4) can be configured to operate either as long as the indoor unit is on, or until the required water temperature is reached.

NOTE Details on pump configuration can be found under "Pump operation configuration" on page 18.

Space heating and cooling

According to the season, the customer will select cooling or heating through the user interface on the indoor unit.

The outdoor unit (1) will operate in cooling mode or heating mode to achieve the target leaving water temperature.

With the unit in heating mode, the 2-way valve (13) is open. Hot water is provided to both the fan coil units and the floor heating loops.

With the unit in cooling mode, the motorised 2-way valve (13) is closed to prevent cold water running through the floor heating loops (FHL).

! When closing several loops in the system by remotely controlled valves, it might be required to install a by-pass valve (9) to avoid the flow switch safety device from being activated. See also "Application 2" on page 3.

! Wiring of the 2-way valve (13) is different for a NC (normal closed) valve and a NO (normal open) valve! Make sure to connect to the correct terminal numbers as detailed on the wiring diagram.

The ON/OFF setting of the heating/cooling operation is done by the user interface on the indoor unit.

OVERVIEW OF THE INDOOR UNIT

Opening the indoor unit

- The front flap on the indoor unit cover gives access to the manometer and user interface, and is equipped with a push lock system. Push to open the front flap.

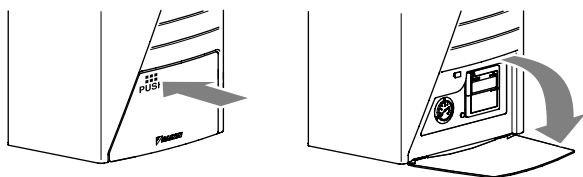

- The indoor unit cover can be removed by removing the 2 side screws and unhitching the cover.
Model shown: EKHBX

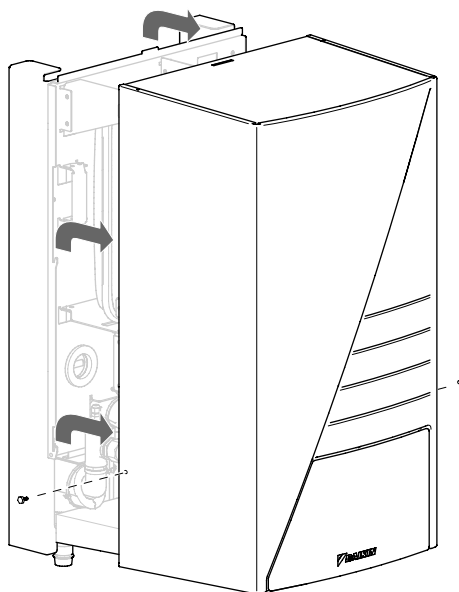

! Make sure to fix the cover with the screws and nylon washers when installing the cover (screws and nylon washers are delivered as accessory).

! Parts inside the unit can be hot.

- To gain access to the switch box' internals – e.g. to connect the field wiring – the switch box service panel can be removed. Thereto, loosen the two front screws and remove the switch box service panel.

! Switch off all power supply — i.e. outdoor unit power supply and backup heater and sanitary water tank power supply (if applicable) — before removing the switch box service panel.

Model shown: EKHBX

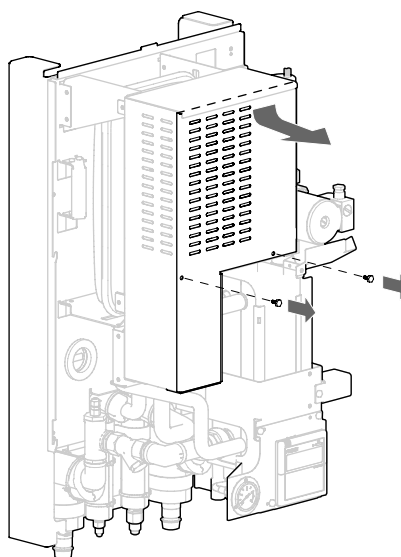

Main components

Model shown: EKHBX (drain pan not shown for clarity)

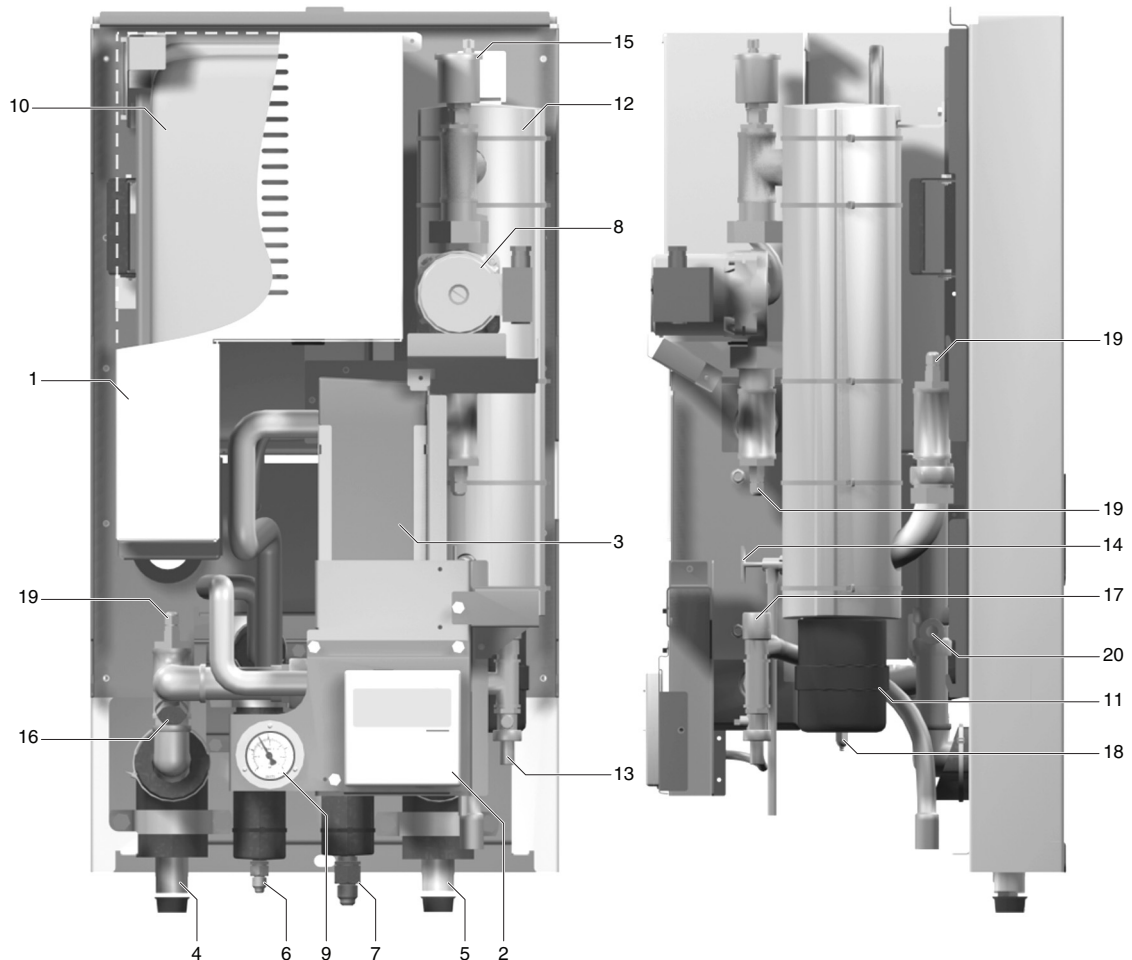

- | | |
|--|--|
| <p>1 Switch box
The switch box contains the main electronic and electrical parts of the indoor unit.</p> <p>2 User interface
The user interface allows the installer and user to set up, use and maintain the unit.</p> <p>3 Heat exchanger</p> <p>4 Water inlet connection</p> <p>5 Water outlet connection</p> <p>6 Refrigerant liquid connection</p> <p>7 Refrigerant gas connection</p> <p>8 Pump
The pump circulates the water in the water circuit.</p> <p>9 Manometer
The manometer allows readout of the water pressure in the water circuit.</p> <p>10 Expansion vessel (10 l)</p> <p>11 Backup heater
The backup heater consists of an electrical heating element that will provide additional heating capacity to the water circuit if the heating capacity of the outdoor unit is insufficient due to low outdoor temperatures.</p> <p>12 Backup heater vessel
The backup heater heats the water in the backup heater vessel.</p> <p>13 Drain and fill valve</p> <p>14 Drain valve backup heater vessel
The drain valve of the backup heater allows draining the remaining water in the backup heater vessel after draining with the drain and fill valve.</p> | <p>15 Air purge valve
Remaining air in the water circuit will be automatically removed via the air purge valve.</p> <p>16 Water filter
The water filter removes dirt from the water to prevent damage to the pump or blockage of the evaporator. The water filter should be cleaned on a regular base. See "Maintenance" on page 24.</p> <p>17 Pressure relief valve
The pressure relief valve prevents excessive water pressure in the water circuit (≥ 3 bar).</p> <p>18 Thermal protector backup heater
The backup heater is equipped with a thermal protector. The thermal protector is activated when the temperature becomes too high. When activated, the white nipple juts out. Press inwards to reset.</p> <p>19 Temperature sensors
Three temperature sensors determine the water temperature at various points in the water circuit.</p> <p>20 Flow switch
The flow switch checks the flow in the water circuit and protects the heat exchanger against freezing and the pump against damage.</p> <p>21 Shut-off valves (accessory, not shown)
The shut-off valves on the water inlet connection and water outlet connection allow isolation of the indoor unit water circuit side from the residential water circuit side. This facilitates draining and filter replacement of the indoor unit.</p> |
|--|--|

Switch box main components

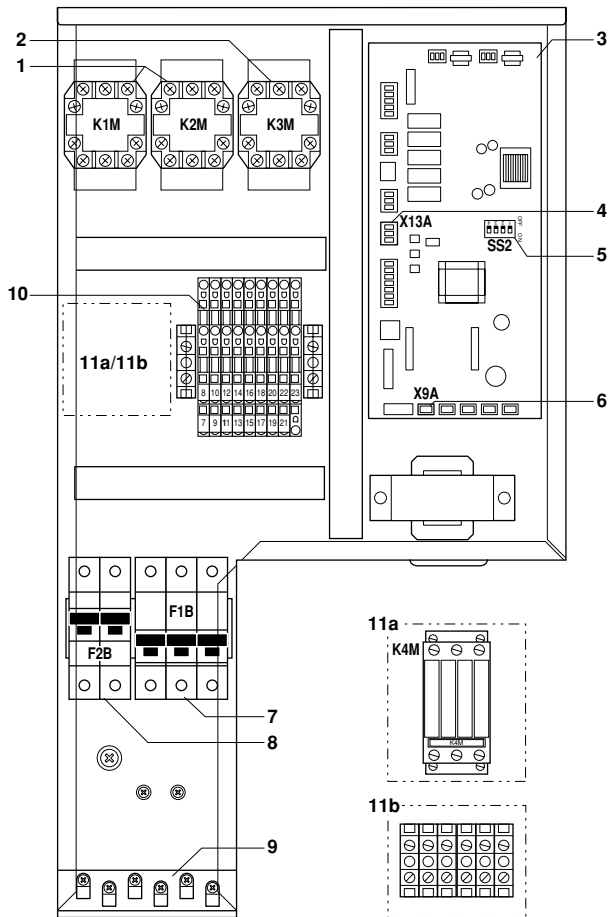

- 1 Backup heater contactors K1M and K2M
- 2 Booster heater contactor K3M (only for installations with sanitary water tank)
- 3 Main PCB
The main PCB (Printed Circuit Board) controls the functioning of the unit.
- 4 X13A socket
The X13A socket receives the K3M connector (only for installations with sanitary water tank).
- 5 DIP switch SS2
The DIP switch SS2 provides 4 toggle switches to configure certain installation parameters. See ["DIP switch settings overview" on page 17](#).
- 6 X9A socket
The X9A socket receives the thermistor connector (only for installations with sanitary water tank).
- 7 Backup heater circuit breaker
The circuit breaker protects the backup heater electrical circuit against overload or short circuit.
- 8 Booster heater circuit breaker (only for installations with sanitary water tank)
The circuit breaker protects the booster heater in the sanitary water tank against overload or short circuit.
- 9 Cable tie mountings
The cable tie mountings allow to fix the field wiring with cable ties to the switch box to ensure strain relief.
- 10 Terminal block
The terminal block allows easy connection of field wiring.
- 11a K4M contactor (for all unit types except for 3V3 unit type)
- 11b Backup heater terminal block (for 3V3 unit type only)

Functional diagram

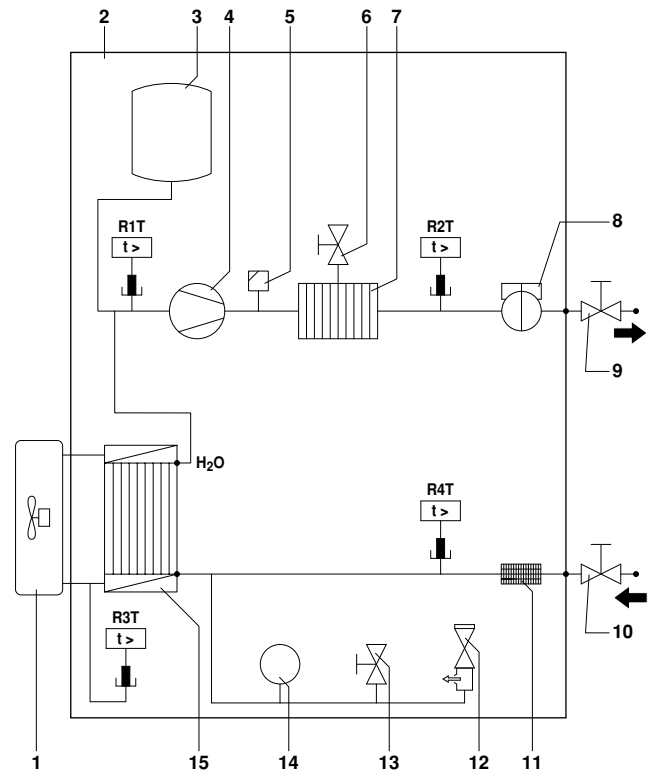

- | | | | |
|---|--|-----|---|
| 1 | Outdoor unit | 10 | Shut-off valve water inlet (filed installation) |
| 2 | Indoor unit | 11 | Filter |
| 3 | Expansion vessel | 12 | Pressure relief valve |
| 4 | Pump | 13 | Fill and drain valve |
| 5 | Air purge valve | 14 | Manometer |
| 6 | Drain valve backup heater vessel | 15 | Heat exchanger |
| 7 | Backup heater vessel with backup heater | R1T | Temperature sensors |
| 8 | Flow switch | R2T | |
| 9 | Shut-off valve water outlet (field installation) | R3T | |
| | | R4T | |

INSTALLATION OF THE INDOOR UNIT

Selecting an installation location

The unit is to be wall mounted in an indoor location that meets the following requirements:

- The installation location is frost-free.
- The space around the unit is adequate for servicing.
- The space around the unit allows for sufficient air circulation.
- There is a provision for condensate drain (only for EKHBX models) and pressure relief valve blow-off.
- The installation surface is a flat and vertical non-combustible wall, capable of supporting the operation weight of the unit (see "Technical specifications" on page 27).
- There is no danger of fire due to leakage of inflammable gas.
- All piping lengths and distances have been taken into consideration.

Requirement	Value
Maximum allowable refrigerant piping length between outdoor unit and indoor unit	30 m
Minimum required refrigerant piping length between outdoor unit and indoor unit	3 m
Maximum allowable height difference between outdoor unit and indoor unit	20 m
Maximum allowable distance between the 3-way valve and the indoor unit (only for installations with sanitary water tank).	3 m
Maximum allowable distance between the sanitary water tank and the indoor unit (only for installations with sanitary water tank). The thermistor cable supplied with the sanitary water tank is 12 m in length.	10 m

NOTE



If the installation is equipped with a sanitary water tank (optional), please refer to "Sanitary water tank (optional)" on page 15 for additional guidelines and requirements.

Dimensions and service space

All models

Wall bracket dimensions

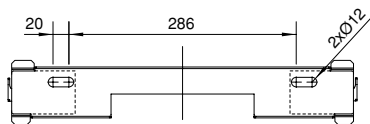

EKHBX (heating/cooling) model

Required service space, see figure 3

	A	B
Setup 1	≥200	⇒ ≥400
Setup 2	≥350	⇒ ≥200

Dimensions, see figure 5

1	Hole for power supply cables	5	Refrigerant gas connection
2	Hole for thermistor cable (to sanitary water tank)	6	Water outlet connection
3	Water inlet connection	7	Drain socket
4	Refrigerant liquid connection	FBSP	Female British Standard Pipe
		MBSP	Male British Standard Pipe

EKHBH (heating only) model

Required service space, see figure 4

	A	B
Setup 1	≥200	⇒ ≥400
Setup 2	≥350	⇒ ≥200

Dimensions, see figure 6

1	Hole for power supply cables	5	Drain of the pressure relief valve
2	Water inlet connection	6	Water outlet connection
3	Refrigerant liquid connection	7	Hole for thermistor cable (to sanitary water tank)
4	Refrigerant gas connection	FBSP	Female British Standard Pipe
		MBSP	Male British Standard Pipe

Inspecting, handling and unpacking the unit

- The indoor unit is packed in a cardboard box, fixed by straps on a wooden pallet.
- At delivery, the unit should be checked and any damage should be reported immediately to the carrier claims agent.
- Check if all indoor unit accessories (see "Accessories" on page 2) are enclosed.
- Bring the unit as close as possible to its final installation position in its original package in order to prevent damage during transport.
- The indoor unit weights approximately 55–65 kg and should be lifted by two persons using the four lifting handles provided.



Do not grasp the switch box to lift the unit! Two lifting handles are provided **behind** the switch box.

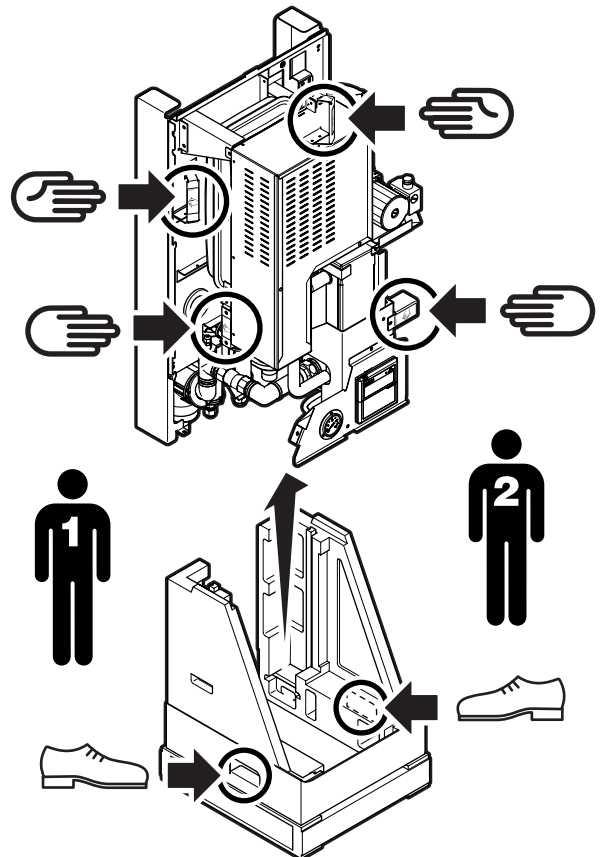

Mounting the indoor unit



The weight of the indoor unit is approximately 55–65 kg. Two persons are required to mount the unit.

- 1 Fix the wall mounting bracket to the wall using appropriate plugs and screws.

Make sure the wall mounting bracket is completely level. Pay special attention to this when installing an EKHBX model to prevent overflow of the drain pan.

- 2 Hang the indoor unit on the wall mounting bracket.
- 3 Fix the indoor unit at the bottom side using appropriate plugs and screws. To do so, the EKHBX models are equipped with 1 fixing hole at the bottom centre of the frame. EKHBH models are equipped with 2 holes at the bottom outer edges of the frame. Insert a 2 mm washer (field supply) between wall and frame to position the unit vertically level.

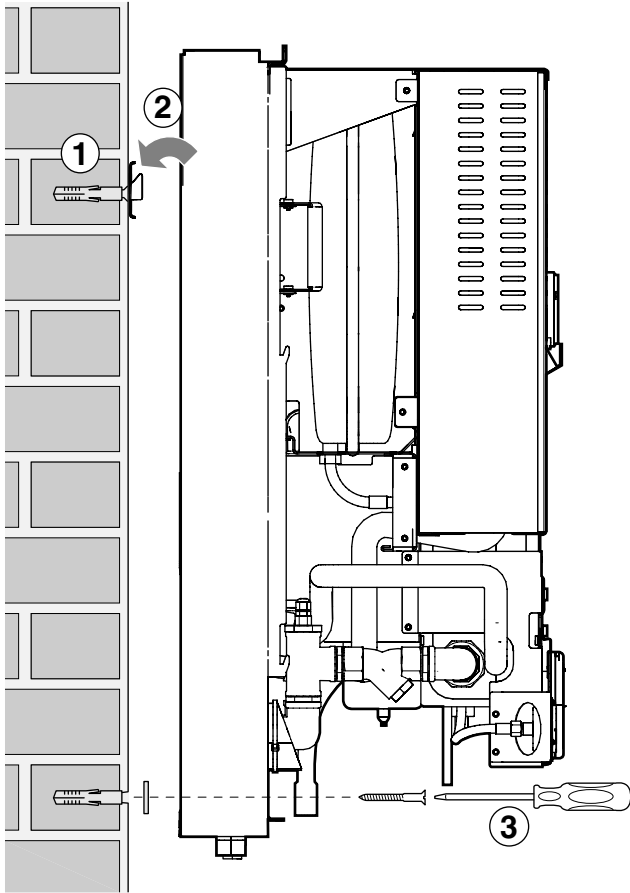

Installation of the drain pan (only for EKHBX models)

For heating/cooling models, it is necessary to install the drain pan (see "Accessories" on page 2).

During cooling operation, water vapour (humidity) in the air might condense to liquid and collect on the cold refrigerant and water pipes. This water is collected in the drain pan, which should be connected to a drain.

For transportation, the drain pan is mounted at the back of the unit. To remove it, proceed as follows:

- 1 Remove tape and remove the screw that fixes the drain pan bracket (L-shaped) to the unit. Keep this screw for reuse when installing the drain pan!
- 2 Remove the transport beam from the drain pan by removing the two screws at the back. Keep both screws for reuse when installing the drain pan!

To install the drain pan, proceed as follows:

- 1 Fix the drain pan to the two back frame tabs. The two required screws are already screwed in the drain pan bottom at delivery.
- 2 Fix the drain pan bracket (L-shaped) to the front frame of the indoor unit with the recuperated screw.
- 3 Fix a suitable drain hose to the drain socket.
- 4 Position the pressure relief valve hose end in the drain pan.

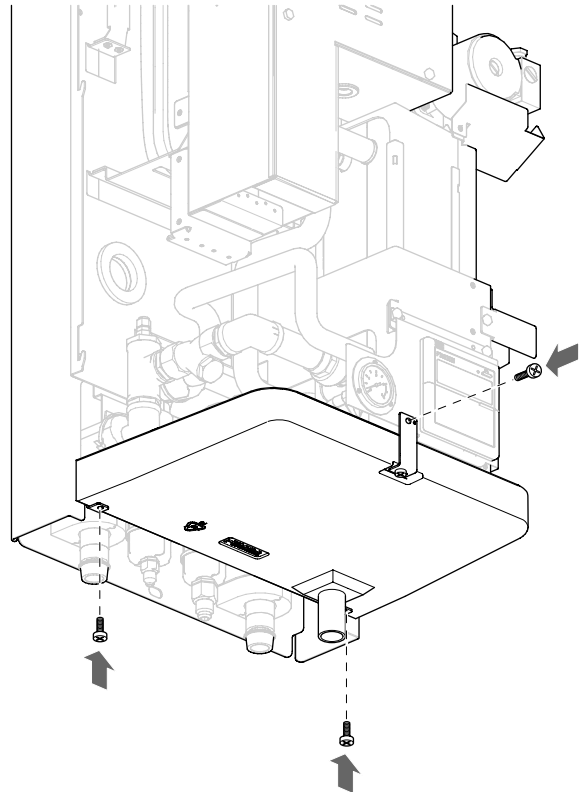

Refrigerant pipework

For all guidelines, instructions and specifications regarding refrigerant pipework between the indoor unit and the outdoor unit, please refer to the outdoor unit installation manual.

The location of the gas pipe and liquid pipe on the indoor unit is shown under "Main components" on page 6.

Refrigerant piping specifications	Indoor unit	Outdoor unit
Gas pipe outer diameter	15.9 mm (5/8 inch)	15.9 mm (5/8 inch)
Liquid pipe outer diameter	6.4 mm (1/4 inch)	6.4 mm (1/4 inch)

Water pipework

Checking the water circuit

The units are equipped with a water inlet and water outlet for connection to a water circuit. This circuit must be provided by a licensed technician and must comply with all relevant European and national regulations.



The unit is only to be used in a closed water system. Application in an open water circuit can lead to excessive corrosion of the water piping.

Before continuing the installation of the unit, check the following points:

- Two shut-off valves are delivered with the unit. To facilitate service and maintenance, install one at the water inlet and one at the water outlet of the indoor unit.
- Drain taps must be provided at all low points of the system to permit complete drainage of the circuit during maintenance. Two drain valves are provided to drain the water from the indoor unit water system.
- Air vents must be provided at all high points of the system. The vents should be located at points which are easily accessible for servicing. An automatic air purge is provided inside the indoor unit. Check that this air purge valve is not tightened too much so that automatic release of air in the water circuit remains possible.
- Take care that the components installed in the field piping can withstand the water pressure.

Checking the water volume and expansion vessel pre-pressure

The unit is equipped with an expansion vessel of 10 litre which has a default pre-pressure of 1 bar.

To assure proper operation of the unit, the pre-pressure of the expansion vessel might need to be adjusted and the minimum and maximum water volume must be checked.

- 1 Check that the total water volume in the installation is 10 l minimum.



In most air conditioning applications this minimum water volume will have a satisfying result.

In critical processes or in rooms with a high heat load though, extra water volume might be required.

- 2 Using the table below, determine if the expansion vessel pre-pressure requires adjustment.

- 3 Using the table and instructions below, determine if the total water volume in the installation is below the maximum allowed water volume.

Installation height difference ^(a)	Water volume	
	<280 l	>280 l
<7 m	No pre-pressure adjustment required.	Actions required: <ul style="list-style-type: none"> • pre-pressure must be decreased, calculate according to "Calculating the pre-pressure of the expansion vessel" • check if the water volume is lower than maximum allowed water volume (use graph below)
>7 m	Actions required: <ul style="list-style-type: none"> • pre-pressure must be increased, calculate according to "Calculating the pre-pressure of the expansion vessel" • check if the water volume is lower than maximum allowed water volume (use graph below) 	Expansion vessel of the unit too small for the installation.

(a) Installation height difference: height difference (m) between the highest point of the water circuit and the indoor unit. If the indoor unit is located at the highest point of the installation, the installation height is considered 0 m.

Calculating the pre-pressure of the expansion vessel

The pre-pressure (Pg) to be set depends on the maximum installation height difference (H) and is calculated as below:

$$Pg = (H/10 + 0.3) \text{ bar}$$

Checking the maximum allowed water volume

To determine the maximum allowed water volume in the entire circuit, proceed as follows:

- 1 Determine for the calculated pre-pressure (Pg) the corresponding maximum water volume using the graph below.
- 2 Check that the total water volume in the entire water circuit is lower than this value.

If this is not the case, the expansion vessel inside the indoor unit is too small for the installation.

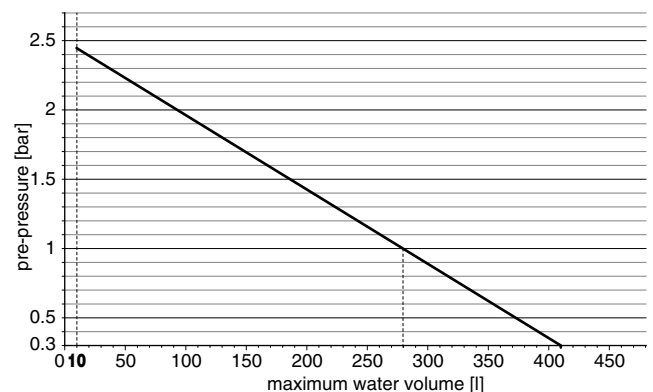

pre-pressure = pre-pressure

maximum water volume = maximum water volume

Example 1

The indoor unit is installed 5 m below the highest point in the water circuit. The total water volume in the water circuit is 100 l.

In this example, no action or adjustment is required.

Example 2

The indoor unit is installed at the highest point in the water circuit.
The total water volume in the water circuit is 350 l.

Result:

- Since 350 l is higher than 280 l, the pre-pressure must be decreased (see table above).
- The required pre-pressure is:
 $P_g = (H/10 + 0.3) \text{ bar} = (0/10 + 0.3) \text{ bar} = 0.3 \text{ bar}$
- The corresponding maximum water volume can be read from the graph: approximately 410 l.
- Since the total water volume (350 l) is below the maximum water volume (410 l), the expansion vessel suffices for the installation.

Setting the pre-pressure of the expansion vessel

When it is required to change the default pre-pressure of the expansion vessel (1 bar), keep in mind the following guidelines:

- Use only dry nitrogen to set the expansion vessel pre-pressure.
- Inappropriate setting of the expansion vessel pre-pressure will lead to malfunction of the system. Therefore, the pre-pressure should only be adjusted by a licensed installer.

Connecting the water circuit

Water connections must be made in accordance with the outlook diagram delivered with the unit, respecting the water in- and outlet.



Be careful not to deform the unit piping by using excessive force when connecting the piping. Deformation of the piping can cause the unit to malfunction.

If air, moisture or dust gets in the water circuit, problems may occur. Therefore, always take into account the following when connecting the water circuit:

- Use clean pipes only.
- Hold the pipe end downwards when removing burrs.
- Cover the pipe end when inserting it through a wall so that no dust and dirt enter.
- Use a good thread sealant for the sealing of the connections. The sealing must be able to withstand the pressures and temperatures of the system.
- When using non-brass metallic piping, make sure to insulate both materials from each other to prevent galvanic corrosion.
- Because brass is a soft material, use appropriate tooling for connecting the water circuit. Inappropriate tooling will cause damage to the pipes.



The unit is only to be used in a closed water system. Application in an open water circuit can lead to excessive corrosion of the water piping.

Charging water

- 1 Connect the water supply to the drain and fill valve (see "Main components" on page 6).
- 2 Fill with water until the manometer indicates a pressure of approximately 2.0 bar. Remove air in the circuit as much as possible using the air purge valves.

NOTE



- During filling, it might not be possible to remove all air in the system. Remaining air will be removed through the automatic air purge valves during first operating hours of the system. Additional filling with water afterwards might be required.
- The water pressure indicated on the manometer will vary depending on the water temperature. (higher pressure at higher water temperature). However, at all times water pressure should remain above 0.3 bar to avoid air entering the circuit.
- The unit might dispose some excessive water through the pressure relief valve.

Piping insulation

The complete water circuit, inclusive all piping, must be insulated to prevent condensation during cooling operation and reduction of the cooling and heating capacity.

Field wiring



WARNING

- Switch off the power supply before making any connections.
- All field wiring and components must be installed by a licensed electrician and must comply with relevant European and national regulations.
- The field wiring must be carried out in accordance with the wiring diagram supplied with the unit and the instructions given below.
- Be sure to use a dedicated power supply. Never use a power supply shared by another appliance.
- Be sure to establish an earth. Do not earth the unit to a utility pipe, surge absorber, or telephone earth. Incomplete earth may cause electrical shock.
- Be sure to install an earth leakage protector. Failure to do so may cause electrical shock.

Overview

The illustration below gives an overview of the required field wiring between several parts of the installation. Refer also to "Typical application examples" on page 3.

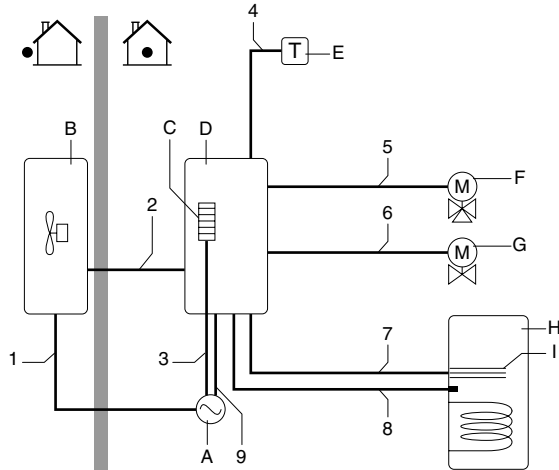

- | | |
|--|---|
| <p>A Dedicated power supply for outdoor unit, backup heater and booster heater (optional)</p> <p>B Outdoor unit</p> <p>C Backup heater</p> <p>D Indoor unit</p> <p>E Room thermostat (field supply, optional)</p> | <p>F 3-way valve for sanitary water tank (field supply, optional)</p> <p>G 2-way valve for cooling mode (field supply, optional)</p> <p>H Sanitary water tank (optional)</p> <p>I Booster heater (optional)</p> |
|--|---|

Item	Description	Required number of conductors	Maximum running current
1	Power supply cable for outdoor unit	2+GND	(a)
2	Indoor unit power supply and communication cable	3+GND	(b)
3	Power supply cable for backup heater	2+GND or 3+GND	(c)
4	Room thermostat cable	3 or 4	100 mA
5	3-way valve control cable	2+GND	100 mA
6	2-way valve control cable	2+GND	100 mA
7	Booster heater power supply and thermal protection cable	4+GND	13 A
8	Thermistor cable	2	(d)
9	Booster heater power supply cable	2+GND	13 A

- (a) Refer to nameplate on outdoor unit
 (b) If length<10 m: cable section 1.5 mm², if length>10 m: cable section 2.5 mm²
 (c) See table under "Connection of the backup heater power supply" on page 14.
 (d) The thermistor and connection wire (12m) are delivered with the sanitary water tank.

Internal wiring - Parts table

Refer to the internal wiring diagram supplied with the unit (inside the indoor unit cover). The abbreviations used are listed below.

- A1P Main PCB
 A2P Remote controller PCB (user interface)
 A3P Thermostat (field supply, PC= internal Power Circuit)
 E1H Backup heater element 1
 E2H Backup heater element 2
 E3H Backup heater element 3
 E4H # Booster heater
 F1B Fuse backup heater
 F2B # Fuse booster heater
 FU1 Fuse 3.15 A T 250 V
 K1M Contactor backup heater step 1
 K2M Contactor backup heater step 2
 K3M # Contactor booster heater
 K4M Contactor backup heater
 M1P Pump
 M2S ## 2-way valve for cooling mode
 M3S # 3-way valve: floor heating/sanitary warm water
 Q1DI Earth leakage protector
 Q1L Thermal protector backup heater
 Q2L # Thermal protector booster heater
 R1T (A1P) Outlet water heat exchanger thermistor
 R1T (A2P) Thermistor (air)
 R2T Outlet water backup heater thermistor
 R3T Refrigerant liquid side thermistor
 R4T Inlet water thermistor
 R5T # SWW (sanitary warm water) thermistor
 S1L Flow switch
 TR1 Transformer 24 V for PCB
 V1S Spark suppression 1
 V2S Spark suppression 2
 X1M Terminal strip (standard part)

- # Applications with sanitary water tank only
 ## Heating/cooling applications only

Field wiring guidelines

- Most field wiring on the indoor unit side is to be made on the terminal block inside the switch box. To gain access to the terminal block, remove the indoor unit cover and switch box service panel, see "Opening the indoor unit" on page 5.
- Cable tie mountings are provided at the bottom of the switch box. Fix all cables using cable ties.
- A dedicated power circuit is required for the backup heater.
- Installations equipped with a sanitary water tank (optional), require a dedicated power circuit for the **booster heater**.

Please refer to "Sanitary water tank (optional)" on page 15 for all wiring specifications.

Only for EKHBX (heating/cooling) models

- The mounting plate of indoor unit is equipped with 2 holes to guide all electrical wiring out of the unit:
 - use the left hole (1) for all power supply cables, thermostat cable (optional), 3-way valve cable (optional) and 2-way valve cable (optional),
 - use the right hole (2) for the thermistor cable to sanitary water tank (optional).

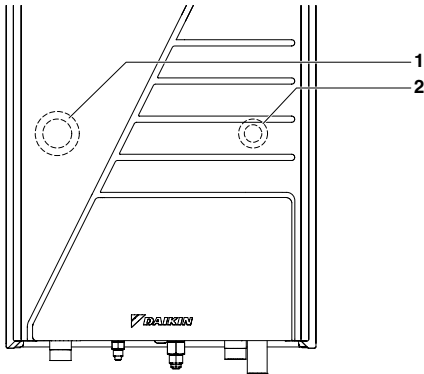

Only for EKHBH (heating only) models

- The bottom plate of indoor unit is equipped with 3 holes to guide all electrical wiring out of the unit:
 - use both bottom-left holes (1) for all power supply cables, thermostat cable (optional), 3-way valve cable (optional) and 2-way valve cable (optional),
 - use the second hole (2) for the thermistor cable to sanitary water tank (optional).

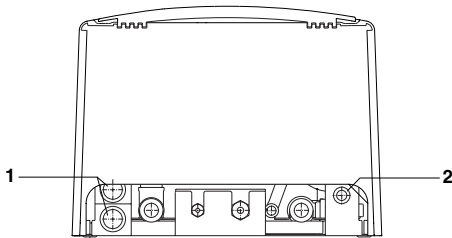

Connection of the indoor unit power supply and communication cable

Power circuit and cable requirements

Power supply for the indoor unit is to be provided through the outdoor unit. Data communication with the outdoor unit is provided through the same cable.

For all guidelines and specifications regarding field wiring between the indoor unit and the outdoor unit, please refer to the outdoor unit installation manual.

Procedure

- 1 Using the appropriate cable, connect the power circuit to the appropriate terminals as shown on the wiring diagram and the illustration below.
- 2 Connect the earth conductor (yellow/green) to the earthing screw on the switch box mounting plate.
- 3 Fix the cable with cable ties to the cable tie mountings to ensure strain relief.

Note: only relevant field wiring is shown.

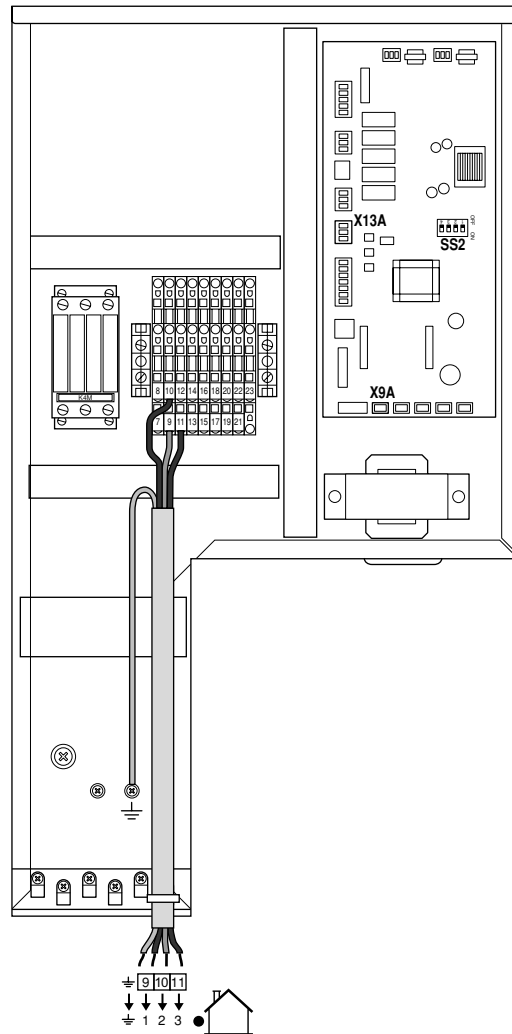

Connection of the backup heater power supply

Power circuit and cable requirements



- Be sure to use a dedicated power circuit for the backup heater. Never use a power circuit shared by another appliance.
- Use one and same dedicated power supply for the outdoor unit, indoor unit, backup heater and booster heater (sanitary water tank).

This power circuit must be protected with the required safety devices according to local and national regulations.

Select the power cable in accordance with relevant local and national regulations. For the maximum running current of the backup heater, refer to the table below.

Indoor unit model	Backup heater capacity	Backup heater nominal voltage	Maximum running current
EKHB*00*A3V3	3 kW	1 x 230 V	13 A
EKHB*00*A6V3	6 kW	1 x 230 V	26 A
EKHB*00*A6W1	6 kW	3 x 400 V	8.6 A
EKHB*00*A9W1	9 kW	3 x 400 V	13 A
EKHB*00*A6T1	6 kW	3 x 230 V	15 A
EKHB*00*A9T1	9 kW	3 x 230 V	23 A

Procedure

- 1 Using the appropriate cable, connect the power circuit to the main circuit breaker as shown on the wiring diagram and the illustration below.
- 2 Connect the earth conductor (yellow/green) to the earthing screw on the switch box mounting plate.
- 3 Fix the cable with cable ties to the cable tie mountings to ensure strain relief.

Note: only relevant field wiring is shown. 3-phase backup heater is shown.

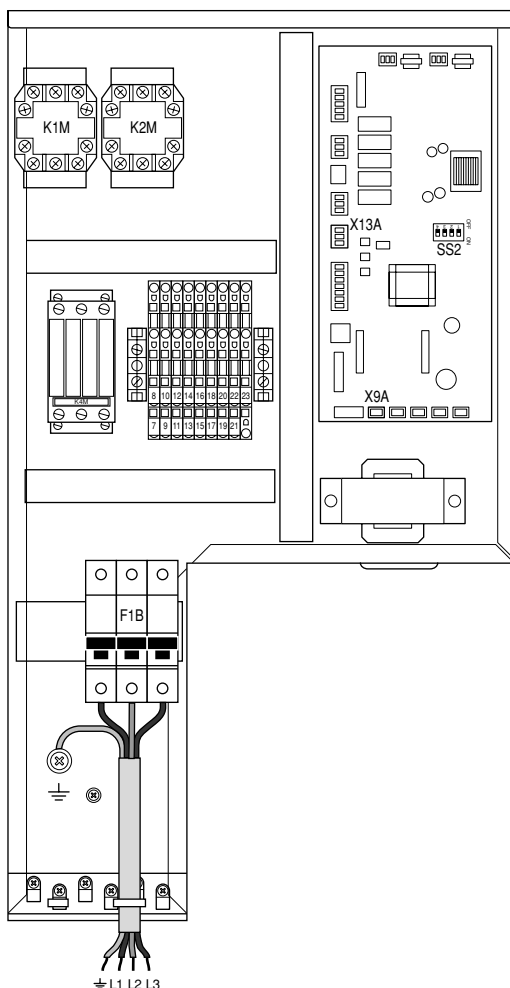

Connection of the sanitary water tank field wiring (optional)

Refer to "Sanitary water tank (optional)" on page 15 for wiring details.

Connection of the thermostat cable

Connection of the thermostat cable depends on the application.

See also "Typical application examples" on page 3 and "Room thermostat installation configuration" on page 17 for more information and configuration options on pump operation in combination with a room thermostat.

Thermostat requirements

- Power supply: 230 V AC or battery operated
- Contact voltage: 230 V.

Procedure

- 1 Connect the thermostat cable to the appropriate terminals as shown on the wiring diagram.

Heating only thermostat

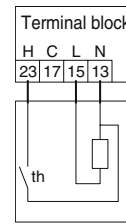

Heating/cooling thermostat

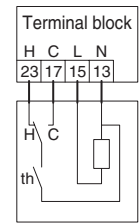

- 2 Fix the cable with cable ties to the cable tie mountings to ensure strain relief.
- 3 Set DIP switch SS2-3 on the PCB to ON. See "Room thermostat installation configuration" on page 17 for more information.

Connection of the valve control cables

Valve requirements

- Power supply: 230 V AC
- Maximum running current: 100 mA

Wiring the 2-way valve

- 1 Using the appropriate cable, connect the valve control cable to the appropriate terminals as shown on the wiring diagram.

NOTE



Wiring is different for a NC (normal closed) valve and a NO (normal open) valve. Make sure to connect to the correct terminal numbers as detailed on the wiring diagram and illustrations below.

Normal closed (NC) 2-way valve

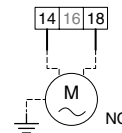

Normal open (NO) 2-way valve

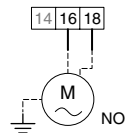

- 2 Fix the cable(s) with cable ties to the cable tie mountings to ensure strain relief.

Wiring the 3-way valve

- 1 Using the appropriate cable, connect the valve control cable to the appropriate terminals as shown on the wiring diagram.



The 3-way valve should be fitted as such that when the 3-way valve is idle (not activated), the space heating circuit is selected.

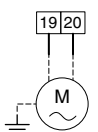

- 2 Fix the cable(s) with cable ties to the cable tie mountings to ensure strain relief.

SANITARY WATER TANK (OPTIONAL)



- The total **altherma**[®] by **DAIKIN** system (indoor unit and outdoor unit) is designed for combination with an **altherma**[®] by **DAIKIN** sanitary water tank. In case another tank is being used in combination with the **altherma**[®] by **DAIKIN** indoor unit, Daikin cannot guarantee neither good operation nor reliability of the system. For those reasons Daikin cannot give warranty of the system in such case.
- For safety reasons, it is not allowed to add ethylene glycol to the water circuit. Adding ethylene glycol might lead to contamination of the sanitary water if a leakage would occur in the heat exchanger coil.
- The sanitary hot water at the hot water connection cannot be used for human consumption.

Main components

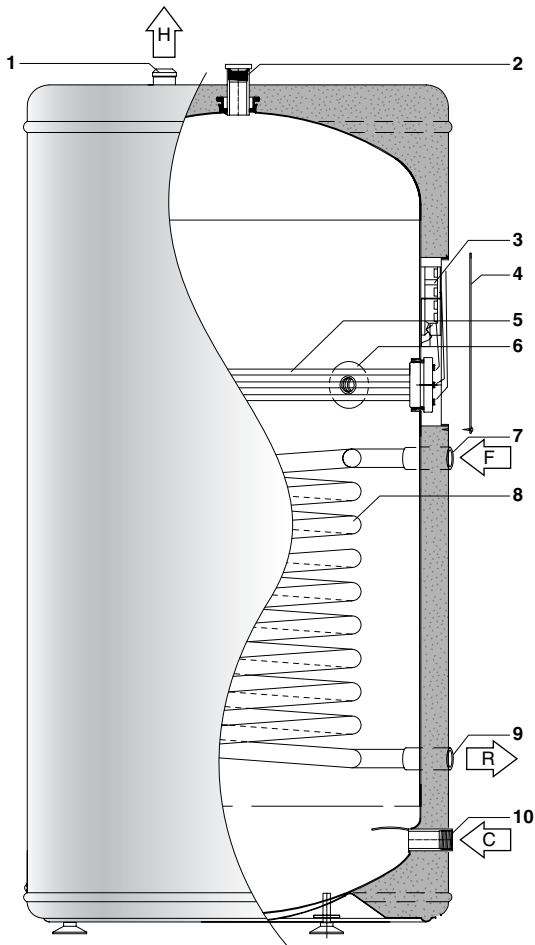

- 1 Hot water connection
- 2 Pressure relief valve connection
- 3 Electrical box
- 4 Electrical box lid
- 5 Booster heater
- 6 Threaded thermistor hole
- 7 Flow inlet connection
- 8 Heat exchanger coil
- 9 Return outlet connection
- 10 Cold water connection

Safety devices

- Thermal protector — The booster heater in the sanitary water tank is equipped with a thermal protector. The thermal protector is activated when the temperature becomes too high. When activated, the protector has to be reset on the sanitary water tank by pressing the red button (for access, remove the electrical box lid).



The electrical box lid must only be opened by a licensed electrician.

Switch off the power supply before opening the electrical box lid.

- Pressure relief valve — A pressure relief valve (field supply) in accordance with relevant local and national regulations, and with an opening pressure of maximum 10 bar must be connected to the pressure relief valve connection.

Outlook diagram

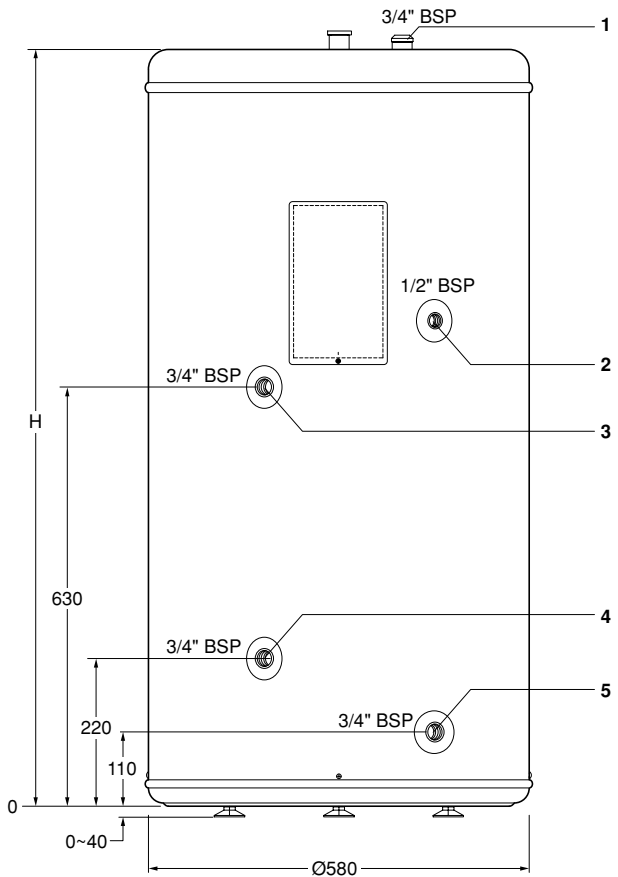

- 1 Hot water connection
- 2 Threaded thermistor hole
- 3 Flow inlet connection (see also "Installation guidelines" on page 16 regarding pipe size to use)
- 4 Return outlet connection (see also "Installation guidelines" on page 16 regarding pipe size to use)
- 5 Cold water connection

Sanitary water tank model	H
EKSWW150V3	900
EKSWW200V3/Z2	1150
EKSWW300V3/Z2	1600

Installation guidelines

Keep in mind the following guidelines when installing the sanitary water tank:

- The installation location is frost-free.
- Make sure to make the piping in size 1" or more (and reduce to 3/4" at the inlet of the tank) as to have sufficient water volume in the piping between indoor unit and sanitary water tank.
- Locate the sanitary water tank in a suitable position to facilitate easy of maintenance; remember access is required to the electrical box.
- Provide a connection for the pressure relief valve blow-off and drain.
- The sanitary water tank model EKSWW150V3 can be floor or wall mounted. In case of wall mounting, wall mounting kit EKWSWW150 is required (separate ordering).

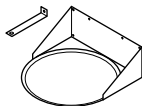

Installing the sanitary water tank

- 1 Check if all sanitary water tank accessories (see "Accessories" on page 2) are enclosed.
- 2 When floor mounting, place the sanitary water tank on a level surface. When wall mounting (only for EKSWW150V3 model), make sure the wall is sturdy. In both cases, make sure the tank is mounted level.
- 3 Screw the thermistor socket in the foreseen threaded thermistor hole in the tank, use a thread sealant such as Teflon or similar to make water tight.
- 4 Apply contact glue to the thermistor and insert the thermistor as deep as possible in the thermistor socket. Fix using the nut provided.

Connecting the water circuits

NOTE



It is important that the 3-way valve is fitted correctly: when the 3-way valve is idle (not activated) the space heating circuit should be selected, when the 3-way valve is activated the sanitary heating circuit should be selected.

- 1 Connect the water inlet and water outlet.
- 2 Connect the hot and cold water supply tubes.
- 3 Connect the pressure relief valve (field supply, opening pressure maximum 10 bar) and drain.

Field wiring



- All field wiring and components must be installed by a licensed electrician and must comply with relevant European and national regulations.
- The field wiring must be carried out in accordance with the wiring diagram supplied with the unit and the instructions given below.
- The sanitary water tank must be earthed via the indoor unit.

Power circuit and cable requirements



- Be sure to use a dedicated power circuit. Never use a power circuit shared by another appliance.
- Use one and same dedicated power supply for the outdoor unit, indoor unit, backup heater and sanitary water tank.

For cable requirements and specifications, refer to "Field wiring" on page 11.

NOTE



Select the power cable in accordance with relevant local and national regulations.

Thermistor cable

The distance between the thermistor cable and power supply cable must always be at least 5 cm to prevent electromagnetic interference on the thermistor cable.

Procedure



Switch off the power supply before making any connections.

Connections to be made in the sanitary water tank electrical box

- 1 Connect the booster heater power supply and thermal protection cable as show in the wiring diagram below.
- 2 Make sure to ensure strain relief of the cable

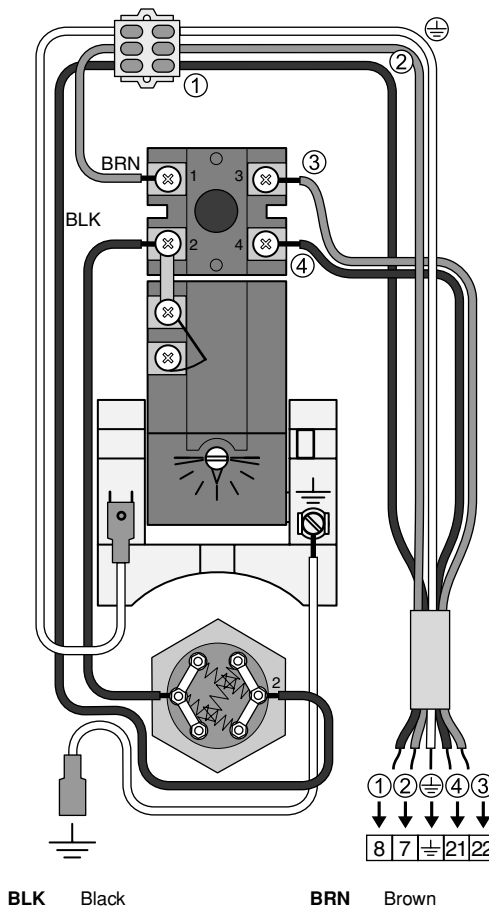

Connections to be made in the indoor unit switch box

- 3 Mount the prewired contactor (K3M) and circuit breaker (F2B). The contactor should be fixed with the two screws supplied.
- 4 Connect the loose ends of the contactor to terminal 7 and 8 on the terminal block and the connector in the socket X13A on the PCB.
- 5 Plug the thermistor cable connector in the socket X9A on the PCB.
- 6 Connect the booster heater power supply and thermal protection cable (field supply) to terminal 7, 8, 21, 22 and earth on the terminal block.
- 7 Connect the booster heater power supply cable to the circuit breaker (F2B) and earthing screw.
- 8 Fix the cables to the cable tie mountings with cable ties to ensure strain relief.
- 9 Set DIP switch SS2-2 on the PCB to ON. See "DIP switch settings overview" on page 17 for more information.

Note: only relevant field wiring is shown.

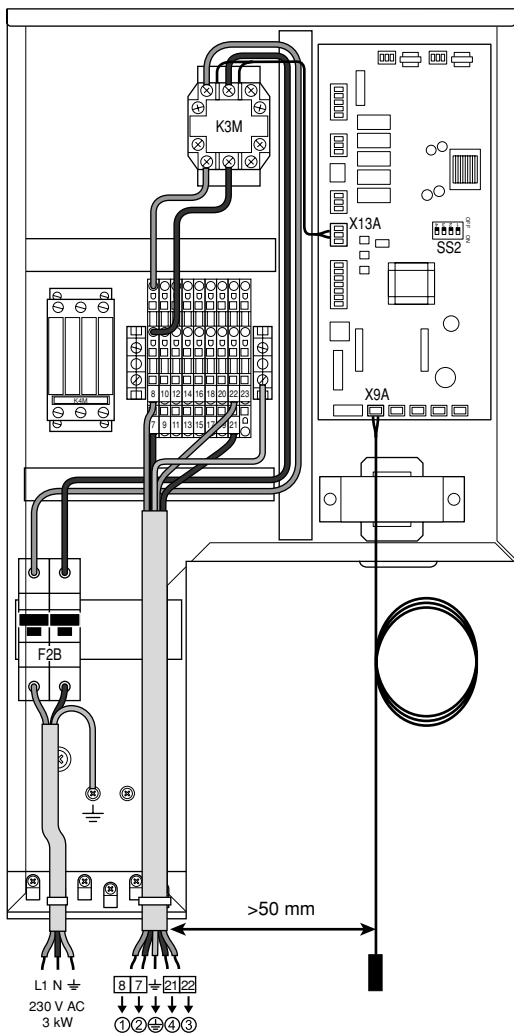

START-UP AND CONFIGURATION

The indoor unit should be configured by the installer to match the installation environment (outdoor climate, installed options, etc.) and user expertise.



It is important that **all** information in this chapter is read sequentially by the installer and that the system is configured as applicable.

DIP switch settings overview

DIP switch SS2 is located on the switch box' PCB (see "Switch box main components" on page 7) and allows configuration of sanitary water tank installation, room thermostat connection and pump operation.



Switch off the power supply before opening the switch box service panel and making any changes to the DIP switch settings.

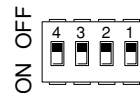

DIP switch SS2	Description	ON	OFF
1	Not applicable for installer	—	(Default)
2	Sanitary water tank installation (see "Sanitary water tank installation configuration" on page 18)	Installed	Not installed
3	Room thermostat connection (see "Room thermostat installation configuration" on page 17)	Room thermostat connected	No room thermostat connected
4	Not used	—	(Default)

Room thermostat installation configuration

- When **no room thermostat** is connected to the indoor unit, toggle switch SS2-3 should be set to **OFF**.

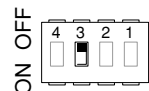

- When a **room thermostat** is connected to the indoor unit, toggle switch SS2-3 should be set to **ON**.

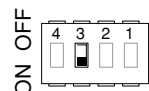

NOTE



- When a room thermostat is connected to the indoor unit, the heating and cooling schedule timers are never available. Other schedule timers are not affected. For more information on the schedule timers, refer to the operation manual.
- When a room thermostat is connected to the indoor unit, and the button or button is pressed, the centralised control indicator will flash to indicate that the room thermostat has priority and controls on/off operation and change over operation.

The following table summarizes the required configuration and thermostat wiring at the terminal block in the switch box. Pump operation is listed in the third column. The three last columns indicate whether the following functionality is available on the user interface (UI) or handled by the thermostat (T):

- space heating or cooling on/off (☑/☒)
- heating/cooling changeover (☑/☒)
- heating and cooling schedule timers (🕒)

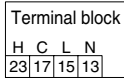
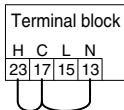
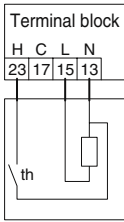
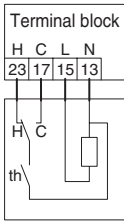
Thermostat	Configuration	Pump operation	☑/☒	☑/☒	🕒
No thermostat	<ul style="list-style-type: none"> • SS2-3 = OFF • wiring: (non) 	determined by leaving water temperature ^(a)	UI	UI	UI
	<ul style="list-style-type: none"> • SS2-3 = ON • wiring: 	on when space heating or cooling is on (☑/☒)	UI	UI	UI
Heating only thermostat	<ul style="list-style-type: none"> • SS2-3 = ON • wiring: 	on when heating request by room thermostat	T	—	—
Thermostat with heating/cooling switch	<ul style="list-style-type: none"> • SS2-3 = ON • wiring: 	on when heating request or cooling request by room thermostat	T	T	—

th = Thermostat contact
 C = Cooling contact
 H = Heating contact
 L, N = 230 V AC

(a) The pump will stop when space heating/cooling is turned off or when the water reaches the desired water temperature as set on the user interface. With space heating/cooling turned on, the pump will then run every 5 minutes during 3 minutes

Pump operation configuration

NOTE To set the pump speed, refer to "Setting the pump speed" on page 19.

Without room thermostat

When no thermostat is connected to the indoor unit, pump operation will be determined by the leaving water temperature.

To force continuous pump operation when no room thermostat is connected do the following:

- set toggle switch SS2-3 to ON,
- short-circuit the terminal numbers 23-17-13 on the terminal block in the switch box.

With room thermostat

When a thermostat is connected to the indoor unit, the pump will operate continuously whenever there is heating or cooling demand requested by the thermostat.

Sanitary water tank installation configuration

- When **no sanitary water tank** is installed, toggle switch SS2-2 should be set to **OFF** (default).

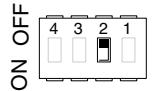

- When a **sanitary water tank** is installed, toggle switch SS2-2 should be set to **ON**.

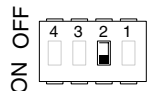

Pre-operation checks

Checks before initial start-up



Switch off the power supply before making any connections.

After the installation of the unit, check the following before switching on the circuit breaker:

- Field wiring**
 Make sure that the field wiring between local supply panel and indoor unit, outdoor unit and indoor unit, indoor unit and valves (when applicable), indoor unit and room thermostat (when applicable), and indoor unit and sanitary water tank has been carried out according to the instructions described in the chapter "Field wiring" on page 11, according to the wiring diagrams and according to European and national regulations.
- Fuses or protection devices**
 Check that the fuses or the locally installed protection devices are of the size and type specified in the chapter "Technical specifications" on page 27. Make sure that neither a fuse nor a protection device has been bypassed.
- Earth wiring**
 Make sure that the earth wires have been connected properly and that the earth terminals are tightened.
- Internal wiring**
 Visually check the switch box on loose connections or damaged electrical components.
- Fixation**
 Check that the unit is properly fixed, to avoid abnormal noises and vibrations when starting up the unit.

- 6 Damaged equipment
Check the inside of the unit on damaged components or squeezed pipes.
- 7 Refrigerant leak
Check the inside of the unit on refrigerant leakage. If there is a refrigerant leak, call your local Daikin dealer.
- 8 Power supply voltage
Check the power supply voltage on the local supply panel. The voltage must correspond to the voltage on the identification label of the unit.
- 9 Shut-off valves
Make sure that the shut-off valves are correctly installed and fully open.



Operating the system with closed valves will damage the pump.

Powering up the indoor unit

When power supply to the indoor unit is turned on, "88" is displayed on the user interface during its initialisation, which might take up to 10 seconds. During this process the user interface cannot be operated.

Setting the pump speed

The pump speed can be selected on the pump (see "Main components" on page 6).

The default setting is highest speed (III). If the water flow in the system is too high (e.g., noise of running water in the installation) the speed can be lowered (I or II).

The available external static pressure (ESP, expressed in mH₂O) in function of the water flow (l/min) is shown in the graph below.

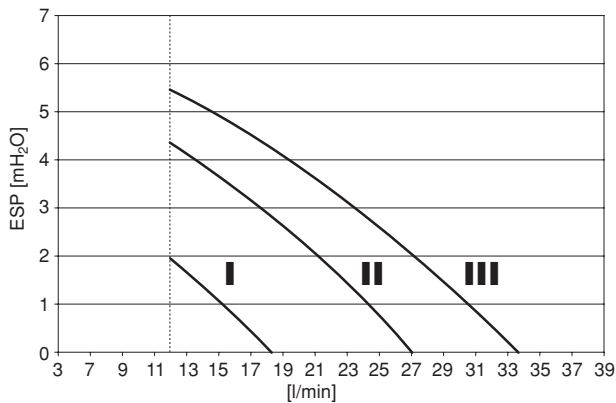

Field settings

The indoor unit should be configured by the installer to match the installation environment (outdoor climate, installed options, etc.) and user demand. Thereto, a number of so called field settings are available. These field settings are accessible and programmable through the user interface on the indoor unit.

Each field setting is assigned a 3-digit number or code, for example [5-03], which is indicated on the user interface display. The first digit [5] indicates the 'first code' or field setting group. The second and third digit [03] together indicate the 'second code'.

A list of all field settings and default values is given under "Field settings table" on page 23. In this same list, we provided for 2 columns to register the date and value of altered field settings at variance with the default value.

A detailed description of each field setting is given under "Detailed description" on page 20.

Procedure

To change one or more field settings, proceed as follows.

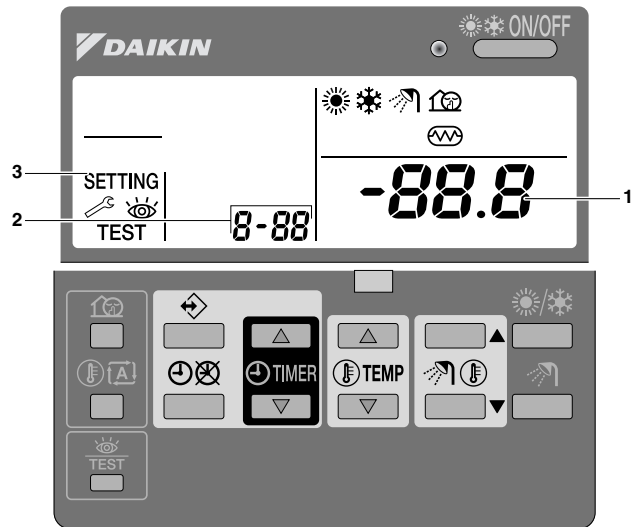

- 1 Press the button for a minimum of 5 seconds to enter FIELD SET MODE.
The **SETTING** icon (3) will be displayed. The current selected field setting code is indicated **8-88** (2), with the set value displayed to the right **888** (1).
- 2 Press the button to select the appropriate field setting first code.
- 3 Press the button to select the appropriate field setting second code.
- 4 Press the button and button to change the set value of the select field setting.
- 5 Save the new value by pressing the button.
- 6 Repeat step 2 through 4 to change other field settings as required.
- 7 When finished, press the button to exit FIELD SET MODE.

NOTE



Changes made to a specific field setting are only stored when the button is pressed. Navigating to a new field setting code or pressing the button will discard the change made.

NOTE



- Before shipping, the set values have been set as shown under "Field settings table" on page 23.
- When exiting FIELD SET MODE, "88" may be displayed on the user interface LCD while the unit initialises itself.

Detailed description

[0] User permission level

If required, certain user interface buttons can be made unavailable for the user.

Three permission levels are defined (see the table below). Switching between level 1 and level 2/3 is done by pressing the buttons \ominus TIMER \blacktriangle and \ominus TIMER \blacktriangledown immediately followed by the buttons Ⓜ , Ⓜ for at least 5 seconds (in normal mode). Note that no indication on the user interface is given. When level 2/3 is selected, the actual permission level — either level 2 or level 3 — is determined by the field setting [0-00].

Button	Permission level		
	1	2	3
Silent mode button	Ⓜ	operable	—
Weather dependent set point button	Ⓜ	operable	—
Schedule timer enable/disable button	Ⓜ	operable	operable
Programming button	Ⓜ	operable	—
Time adjust buttons	\ominus TIMER \blacktriangle \ominus TIMER \blacktriangledown	operable	—
Inspection/test operation button	Ⓜ	operable	—

[1] Weather dependent set point (heating operation only)

The weather dependent set point field settings define the parameters for the weather dependent operation of the unit. When weather dependent operation is active the water temperature is determined automatically depending on the outdoor temperature: colder outdoor temperatures will result in warmer water and vice versa. During weather dependent operation, the user has the possibility to shift up or down the target water temperature by a maximum of 5°C. See the operation manual for more details on weather dependent operation.

- [1-00] Low ambient temperature (Lo_A): low outdoor temperature.
- [1-01] High ambient temperature (Hi_A): high outdoor temperature.
- [1-02] Set point at low ambient temperature (Lo_Ti): the target outgoing water temperature when the outdoor temperature equals or drops below the low ambient temperature (Lo_A).
Note that the Lo_Ti value should be *higher* than Hi_Ti, as for colder outdoor temperatures (i.e. Lo_A) warmer water is required.
- [1-03] Set point at high ambient temperature (Hi_Ti): the target outgoing water temperature when the outdoor temperature equals or rises above the high ambient temperature (Hi_A).
Note that the Hi_Ti value should be *lower* than Lo_Ti, as for warmer outdoor temperatures (i.e. Hi_A) less warm water suffices.

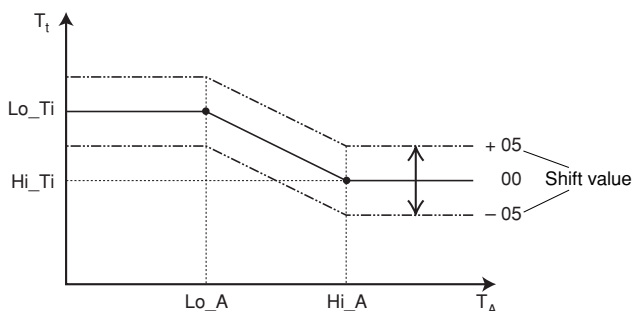

T_t Target water temperature
 T_A Ambient (outdoor) temperature

Shift value = Shift value

[2] Disinfection function

Applies only to installations with a sanitary water tank.

The disinfection function disinfects the sanitary water tank by periodically heating the sanitary water to a specific temperature.



The disinfection function field settings should be configured by the installer according to national and local regulations.

- [2-00] Operation interval: day(s) of the week at which the sanitary water should be heated.
- [2-01] Status: defines whether the disinfection function is turned on (1) or off (0).
- [2-02] Start time: time of the day at which the sanitary water should be heated.
- [2-03] Set point: high water temperature to be reached.
- [2-04] Interval: time period defining how long the set point temperature should be maintained.

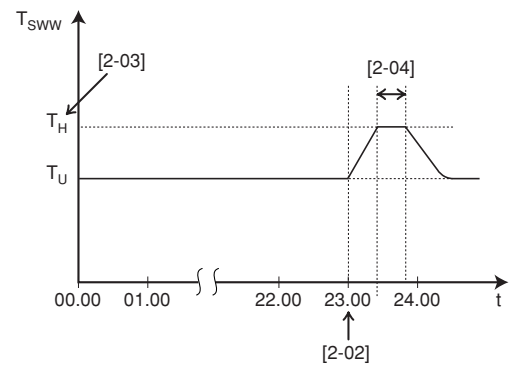

T_{sww} Sanitary water temperature
 T_U User set point temperature (as set on the user interface)
 T_H High set point temperature [2-03]
 t Time

[3] Auto restart

When power returns after a power supply failure, the auto restart function reapplies the user interface settings at the time of the power supply failure.

NOTE It is therefor recommended to leave the auto restart function enabled.

Note that with the function disabled the schedule timer will not be activated when power returns to the unit after a power supply failure. Press the Ⓜ button to enable the schedule timer again.

- [3-00] Status: defines whether the auto restart function is turned on (0) or off (1).

[4] Backup heater operation

The operation of the backup heater can be enabled or disabled.

- [4-00] Status: defines whether backup heater operation is enabled (1) or disabled (0).

[5] Equilibrium temperature and space heating priority temperature

Equilibrium temperature — The 'equilibrium temperature' field settings apply to operation of the **backup heater**. When the equilibrium temperature function is enabled, operation of the backup heater is restricted to low outdoor temperatures, i.e. when the outdoor temperature equals or drops below the specified equilibrium temperature. When the function is disabled, operation of the backup heater is possible at all outdoor temperatures. Enabling this function reduces the working time of the backup heater.

- [5-00] Equilibrium temperature status: specifies whether the equilibrium temperature function is enabled (1) or disabled (0).
- [5-01] Equilibrium temperature: outdoor temperature below which operation of the backup heater is allowed.

Space heating priority temperature (applies only to installations with a sanitary water tank) — The 'space heating priority temperature' field settings apply to operation of the 3-way valve and the **booster heater** in the sanitary water tank.

When the space heating priority function is enabled, it is assured that the full capacity of the heat pump is used for space heating only when the outdoor temperature equals or drops below the specified space heating priority temperature, i.e. low outdoor temperature. In this case the sanitary water will only be heated by the booster heater.

- [5-02] Space heating priority status: specifies whether space heating priority is enabled (1) or disabled (0).
- [5-03] Space heating priority temperature: outdoor temperature below which the sanitary water will be heated by the booster heater only, i.e. low outdoor temperature.
- [5-04] Set point correction for sanitary water temperature: set point correction for the desired sanitary water temperature, to be applied at low outdoor temperature when space heating priority is enabled. The corrected (higher) set point will make sure that the *total* heat capacity of the water in the tank remains approximately unchanged, by compensating for the colder bottom water layer of the tank (because the heat exchanger coil is not operational) with a warmer top layer.

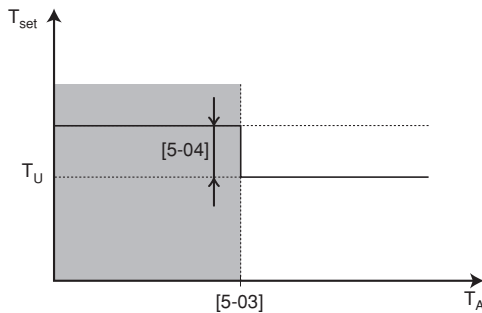

- T_{set} Sanitary water set point temperature
- T_U User set point (as set on the user interface)
- T_A Ambient (outdoor) temperature
- Space heating priority

[6] DT for sanitary water heating

Applies only to installations with a sanitary water tank.

The 'DT (delta temperature) for sanitary water heating' field settings determine the temperatures at which heating of the sanitary water by the heat pump will be started (i.e., the heat pump ON temperature) and stopped (i.e., the heat pump OFF temperature).

When the sanitary water temperature drops below the heat pump ON temperature ($T_{HP\ ON}$), heating of the sanitary water by the heat pump will be started. As soon as the sanitary water temperature reaches the heat pump OFF temperature ($T_{HP\ OFF}$) or the user set point temperature (T_U), heating of the sanitary water by the heat pump will be stopped (by switching the 3-way valve).

The heat pump OFF temperature, and the heat pump ON temperature, and its relation with field settings [6-00] and [6-01] are explained in the illustration below.

- [6-00] Start: temperature difference determining the heat pump ON temperature ($T_{HP\ ON}$). See illustration.
- [6-01] Stop: temperature difference determining the heat pump OFF temperature ($T_{HP\ OFF}$). See illustration.

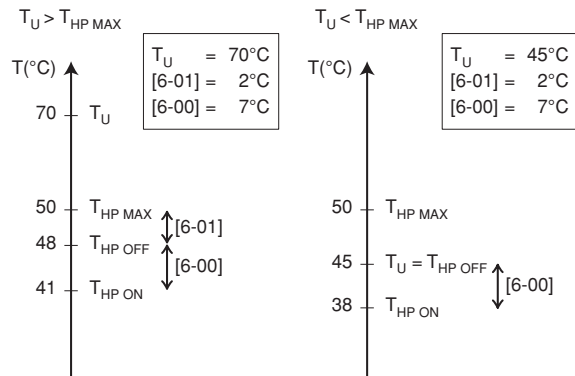

- T_U User set point temperature (as set on the user interface)
- $T_{HP\ MAX}$ Maximum heat pump temperature at sensor in sanitary water tank (50°C)
- $T_{HP\ OFF}$ Heat pump OFF temperature
- $T_{HP\ ON}$ Heat pump ON temperature

[7] Sanitary water step length

Applies only to installations with a sanitary water tank.

When the sanitary water is heated and the sanitary water set point temperature (as set by the user) has been reached, the booster heater will continue to heat the sanitary water to a temperature a few degrees above the set point temperature, i.e. the booster heater OFF temperature. These extra degrees are specified by the sanitary water step length field setting. Correct setting prevents the booster heater from repeatedly turning on and off (i.e. chattering) to maintain the sanitary water set point temperature. Note: the booster heater will turn back on when the sanitary water temperature drops 2°C (fixed value) below the booster heater OFF temperature.

NOTE If the schedule timer for booster heater (see the operation manual) is active, the booster heater will only operate if allowed by this schedule timer.

- [7-00] Sanitary water step length: temperature difference above the sanitary water set point temperature before the booster heater is turned off.

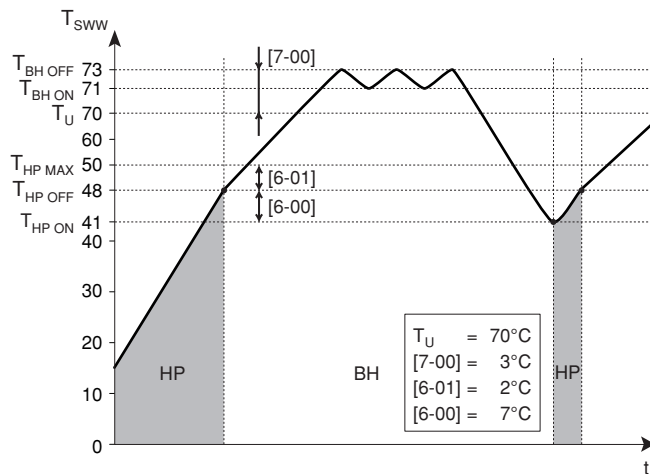

BH	Booster heater
HP	Heat pump. If heating up time by the heat pump takes too long, auxiliary heating by the booster heater can take place
$T_{BH\ OFF}$	Booster heater OFF temperature ($T_U + [7-00]$)
$T_{BH\ ON}$	Booster heater ON temperature ($T_{BH\ OFF} - 2^\circ\text{C}$)
$T_{HP\ MAX}$	Maximum heat pump temperature at sensor in sanitary water tank (50°C)
$T_{HP\ OFF}$	Heat pump OFF temperature ($T_{HP\ MAX} - [6-01]$)
$T_{HP\ ON}$	Heat pump ON temperature ($T_{HP\ OFF} - [6-00]$)
T_{SWW}	Sanitary water temperature
T_U	User set point temperature (as set on the user interface)
t	Time

[8] Sanitary water heating mode timer

Applies only to installations with a sanitary water tank.

The 'sanitary water heating mode timer' field settings defines the minimum and maximum sanitary water heating times, and minimum time between two sanitary water heating cycles.

- [8-00] Minimum running time: specifies the minimum time period during which sanitary water heating should be activated, even when the target sanitary water temperature has already been reached.
- [8-01] Maximum running time: specifies the maximum time period during which sanitary water heating can be activated, even when the target sanitary water temperature has not yet been reached. Note that when the unit is configured to work with a room thermostat (refer to "Room thermostat installation configuration" on page 17), the maximum running timer will only be taken into account when there is a request for space cooling or space heating. When there is no request for room cooling or room heating, sanitary water heating by the heat pump will continue until the "heat pump OFF temperature" (see field settings [5]) is reached. When no room thermostat is installed, the timer is always taken into account.
- [8-02] Anti-recycling time: specifies the minimum required interval between two sanitary water heating cycles.

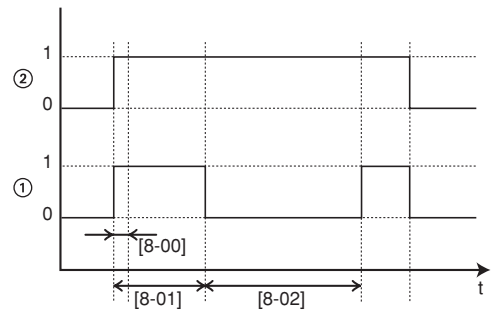

- 1 Sanitary water heating (1 = active, 0 = not active)
- 2 Hot water request (1 = request, 0 = no request)
- t Time

[9] Cooling and heating set points

The purpose of this field setting is to prevent the user from selecting a wrong (i.e., too hot or too cold) leaving water temperature. Thereby the heating temperature set point range and the cooling temperature set point range available to the user can be configured.



- In case of a floor heating application, it is important to limit the maximum leaving water temperature at heating operation according to the specifications of the floor heating installation.
- In case of a floor cooling application, it is important to limit the minimum leaving water temperature at cooling operation to 16°C to prevent condensation on the floor.

- [9-00] Heating set point upper limit: maximum leaving water temperature for heating operation.
- [9-01] Heating set point lower limit: minimum leaving water temperature for heating operation.
- [9-02] Cooling set point upper limit: maximum leaving water temperature for cooling operation.
- [9-03] Cooling set point lower limit: minimum leaving water temperature for cooling operation.

Field settings table











First code	Second code	Setting name	Installer setting at variance with default value				Default value	Range	Step	Unit
			Date	Value	Date	Value				
0	User permission level									
00	User permission level						3	2~3	1	—
1	Weather dependent set point									
00	Low ambient temperature (Lo_A)						-10	-20~5	1	°C
01	High ambient temperature (Hi_A)						15	10~20	1	°C
02	Set point at low ambient temperature (Lo_Tl)						40	25~55	1	°C
03	Set point at high ambient temperature (Hi_Tl)						25	25~55	1	°C
2	Disinfection function									
00	Operation interval						Fri	Mon~Sun, All	—	—
01	Status						1 (ON)	0/1	—	—
02	Start time						23:00	0:00~23:00	1:00	hour
03	Set point						70	40~80	5	°C
04	Interval						10	5~60	5	min
3	Auto restart									
00	Status						0 (ON)	0/1	—	—
4	Backup heater operation									
00	Status						1 (ON)	0/1	—	—
5	Equilibrium temperature and space heating priority temperature									
00	Equilibrium temperature status						1 (ON)	0/1	—	—
01	Equilibrium temperature						0	-15~20	1	°C
02	Space heating priority status						0 (OFF)	0/1	—	—
03	Space heating priority temperatures						0	-15~20	1	°C
04	Set point correction for sanitary water temperature						10	0~20	1	°C
6	DT for sanitary water heating									
00	Start						7	0~20	1	°C
01	Stop						2	0~10	1	°C
7	Sanitary water step length									
00	Sanitary water step length						3	2~4	1	°C
8	Sanitary water heating mode timer									
00	Minimum running time						1	0~5	1	min
01	Maximum running time						30	5~60	5	min
02	Anti-recycling time						3	0~10	0.5	hour
9	Cooling and heating set point ranges									
00	Heating set point upper limit						55	37~55	1	°C
01	Heating set point lower limit						30	30~37	1	°C
02	Cooling set point upper limit						20	18~20	1	°C
03	Cooling set point lower limit						7	7~18	1	°C



TEST RUN AND FINAL CHECK

The installer is obliged to verify correct operation of the indoor and outdoor unit after installation.

Test run operation

Procedure

- 1 Push the  button 4 times so the **TEST** icon will be displayed.
- 2 Depending on the indoor unit model, heating operation, cooling operation or both must be tested as follows (when no action is performed, the user interface will return to normal mode after 10 seconds or by pressing the  button once):
 - To test the heating operation push the  button so the  icon is displayed. To start the test run operation press the  button.
 - To test the cooling operation push the  button so the  icon is displayed. To start the test run operation press the  button.
 - To test the sanitary operation push the  button. The test run operation will start without pressing the  button.
- 3 The test run operation will end automatically after 30 minutes or when reaching the set temperature. The test run operation can be stopped manually by pressing the  button once. If there are misconnections or malfunctions, an error code will be displayed on the user interface. Otherwise, the user interface will return to normal operation.
- 4 To resolve the error codes, see "[Error codes](#)" on page 26.

NOTE  To display the last resolved error code, push the  button 1 time. Push the  button again 4 times to return to normal mode.

NOTE  It is not possible to test run if a forced operation from the outdoor unit is in progress. Should forced operation be started during a test run, the test run will be aborted.

Final check

Before switching on the unit, read following recommendations:

- When the complete installation and all necessary settings have been carried out, close all front panels of the unit and refit the indoor unit cover.
- The service panel of the switch box may only be opened by a licensed electrician for maintenance purposes.

MAINTENANCE

In order to ensure optimal availability of the unit, a number of checks and inspections on the unit and the field wiring have to be carried out at regular intervals.



- Before carrying out any maintenance or repair activity, always switch off the circuit breaker on the supply panel, remove the fuses or open the protection devices of the unit.
- Make sure that before starting any maintenance or repair activity, also the power supply to the outdoor unit is switched off.

The described checks must be executed at least **once a year**.

- 1 **Water pressure**
Check if the water pressure is above 0.3 bar. If necessary add water.
- 2 **Water filter**
Clean the water filter.
- 3 **Water pressure relief valve**
Check for correct operation of the pressure relief valve by turning the red knob on the valve counter-clockwise:
 - If you do not hear a clacking sound, contact your local Daikin dealer.
 - In case the water keeps running out of the unit, close both the water inlet and outlet shut-off valves first and then contact your local Daikin dealer.
- 4 **Sanitary water tank pressure relief valve (field supply)**
Applies only to installations with a sanitary water tank.
Check for correct operation of the pressure relief valve on the sanitary water tank.
- 5 **Sanitary water tank booster heater**
Applies only to installations with a sanitary water tank.
It is advisable to remove lime buildup on the booster heater to extend its life span, especially in regions with hard water. To do so, drain the sanitary water tank, remove the booster heater from the sanitary water tank and immerse in a bucket (or similar) with lime-removing product for 24 hours.
- 6 **Indoor unit switch box**
 - Carry out a thorough visual inspection of the switch box and look for obvious defects such as loose connections or defective wiring.
 - Check for correct operation of contactors K1M, K2M, K3M (applications with sanitary water tank only) and K4M by use of an ohmmeter. All contacts of these contactors must be in open position.

TROUBLESHOOTING

This section provides useful information for diagnosing and correcting certain troubles which may occur in the unit.

General guidelines

Before starting the troubleshooting procedure, carry out a thorough visual inspection of the unit and look for obvious defects such as loose connections or defective wiring.

Before contacting your local Daikin dealer, read this chapter carefully, it will save you time and money.



When carrying out an inspection on the switch box of the unit, always make sure that the main switch of the unit is switched off.

When a safety device was activated, stop the unit and find out why the safety device was activated before resetting it. Under no circumstances safety devices may be bridged or changed to a value other than the factory setting. If the cause of the problem cannot be found, call your local Daikin dealer.

General symptoms

Symptom 1: The unit is turned on (LED is lit) but the unit is not heating or cooling as expected

POSSIBLE CAUSES	CORRECTIVE ACTION
The temperature setting is not correct.	Check the controller set point.
The water flow is too low.	<ul style="list-style-type: none"> Check that all shut off valves of the water circuit are completely open. Check if the water filter needs cleaning. Make sure there is no air in the system (purge air). Check on the manometer that there is sufficient water pressure. The water pressure must be >0.3 bar (water is cold), >>0.3 bar (water is hot). Check that the pump speed setting is on the highest speed (III). Make sure that the expansion vessel is not broken. Check that the resistance in the water circuit is not too high for the pump (refer to "Setting the pump speed" on page 19).
The water volume in the installation is too low.	Make sure that the water volume in the installation is above the minimum required value (refer to "Checking the water volume and expansion vessel pre-pressure" on page 10).

Symptom 2: The unit is turned on but the compressor is not starting (space heating or sanitary heating)

POSSIBLE CAUSES	CORRECTIVE ACTION
The unit must start up out of its operation range (the water temperature is too low).	<p>In case of low water temperature, the system utilizes the backup heater to reach the minimum water temperature first (15°C).</p> <ul style="list-style-type: none"> Check that the backup heater power supply is correct. Check that the backup heater fuse is closed.

Symptom 3: Pump is making noise (cavitation)

POSSIBLE CAUSES	CORRECTIVE ACTION
There is air in the system.	Purge air.
Water pressure at pump inlet is too low.	<ul style="list-style-type: none"> Check on the manometer that there is sufficient water pressure. The water pressure must be >0.3 bar (water is cold), >>0.3 bar (water is hot). Check that the manometer is not broken. Check that the expansion vessel is not broken. Check that the setting of the pre-pressure of the expansion vessel is correct (refer to "Setting the pre-pressure of the expansion vessel" on page 11).

Symptom 4: The water pressure relief valve opens

POSSIBLE CAUSES	CORRECTIVE ACTION
The expansion vessel is broken.	Replace the expansion vessel.
The water volume in the installation is too high.	Make sure that the water volume in the installation is under the maximum allowed value (refer to "Checking the water volume and expansion vessel pre-pressure" on page 10).

Symptom 5: The water pressure relief valve leaks

POSSIBLE CAUSES	CORRECTIVE ACTION
Dirt is blocking the water pressure relief valve outlet.	<p>Check for correct operation of the pressure relief valve by turning the red knob on the valve counter clockwise:</p> <ul style="list-style-type: none"> If you do not hear a clacking sound, contact your local Daikin dealer. In case the water keeps running out of the unit, close both the water inlet and outlet shut-off valves first and then contact your local Daikin dealer.

Symptom 6: The user interface displays "NOT AVAILABLE" when pressing certain buttons

POSSIBLE CAUSES	CORRECTIVE ACTION
The current permission level is set to a level that prevents using the pressed button.	Change the "user permission level" field setting ([0-00], see "Field settings" on page 19).

Symptom 7: Space heating capacity shortage at low outdoor temperatures





POSSIBLE CAUSES	CORRECTIVE ACTION
Backup heater operation is not activated.	<p>Check that the "backup heater operation status" field setting [4-00] is turned on, see "Field settings" on page 19.</p> <p>Check whether or not the thermal protector of the backup heater has been activated (refer to Main components, "Thermal protector backup heater" on page 6 for location of the reset button).</p>
The backup heater equilibrium temperature has not been configured correctly.	Raise the "equilibrium temperature" field setting [5-01] to activate backup heater operation at a higher outdoor temperature.
Too much heat pump capacity is used for heating sanitary water (applies only to installations with a sanitary water tank).	<p>Check that the "space heating priority temperature" field settings are configured appropriately:</p> <ul style="list-style-type: none"> Make sure that the "space heating priority status" field setting [5-02] is enabled. Raise the "space heating priority temperature" field setting [5-03] to activate booster heater operation at a higher outdoor temperature.

Error codes

When a safety device is activated, the user interface LED will be flashing, and an error code will be displayed.

A list of all errors and corrective actions can be found in the table below.

Reset the safety by turning the unit OFF and back ON.

Instruction to turn the unit OFF			
User interface mode (heating/cooling) 	Sanitary water heating mode 	Push the  button	Push the  button
ON	ON	1 time	1 time
ON	OFF	1 time	—
OFF	ON	—	1 time
OFF	OFF	—	—

In case this procedure for resetting the safety is not successful, contact your local Daikin dealer.

Error code	Failure cause	Corrective action
81	Outlet water temperature thermistor failure (outlet water temperature sensor broken)	Contact your local Daikin dealer.
89	Water heat exchanger freeze-up failure (due water flow too low)	Refer to error code 7H.
	Water heat exchanger freeze-up failure (due to refrigerant shortage)	Contact your local Daikin dealer.
7H	Flow failure (water flow too low or no water flow at all, minimum required water flow is 9 l/min)	<ul style="list-style-type: none"> Check that all shut off valves of the water circuit are completely open. Check if the water filter needs cleaning. Make sure there is no air in the system (purge air). Check on the manometer that there is sufficient water pressure. The water pressure must be >0.3 bar (water is cold), >>0.3 bar (water is hot). Check that the pump speed setting is on the highest speed (III). Make sure that the expansion vessel is not broken. Check that the resistance in the water circuit is not too high for the pump (refer to "Setting the pump speed" on page 19). If this error occurs at defrost operation (during space heating or sanitary heating), make sure that the backup heater power supply is wired correctly and that fuses are not blown.
8H	Outlet water temperature of indoor unit too high (>65°C)	<ul style="list-style-type: none"> Check that the contactor of the electric backup heater is not short circuited. Check that the outlet water thermistor is giving the correct read out.
R1	Indoor unit PCB defective	Contact your local Daikin dealer.
R5	Too low (during cooling operation) or too high (during heating operation) refrigerant temperature (measured by R3T)	Contact your local Daikin dealer.
RR	Booster heater thermal protector is open (applies only to installations with a sanitary water tank)	Reset the thermal protector (refer to "Safety devices" on page 15 for location of the reset button)
EO	Flow switch failure (flow switch remains closed while pump is stopped)	Check that the flow switch is not clogged with dirt.
E4	Heat exchanger thermistor failure (heat exchanger temperature sensor broken)	Contact your local Daikin dealer.
E1	Outdoor unit PCB defective	Contact your local Daikin dealer.
E5	Overload activation of compressor	Check that the unit is operating within its operating range (refer to "Technical specifications" on page 27). Contact your local Daikin dealer.
E6	Compressor start-up failure	Contact your local Daikin dealer.
E7	Fan lock failure (fan is locked)	Check if the fan is not obstructed by dirt. If the fan is not obstructed, contact your local Daikin dealer.

Error code	Failure cause	Corrective action
E8	Overcurrent failure	Check that the unit is operating within its operating range (refer to "Technical specifications" on page 27).
ER	Cooling/heating switching failure (only for models with cooling and heating)	Contact your local Daikin dealer.
EC	Sanitary water temperature too high (>89°C)	<ul style="list-style-type: none"> Check that the contactor of the electric booster heater is not short circuited. Check that the sanitary water thermistor is giving the correct read out.
F3	Too high discharge temperature (e.g. due to outdoor coil blockage)	Clean the outdoor coil. If the coil is clean, contact your local Daikin dealer.
F6	Too high condensing pressure during cooling (e.g. due to outdoor coil blocked by dirt)	Clean the outdoor coil. If the coil is clean, contact your local Daikin dealer.
	Too high condensing pressure during cooling (e.g. due to unit operating outside its operating range)	Check that the unit is operating within its operating range (refer to "Technical specifications" on page 27).
FR	High pressure failure (due to unit operating outside its operating range)	Check that the unit is operating within its operating range (refer to "Technical specifications" on page 27).
H0	Voltage and current sensor failure (sensor broken)	Contact your local Daikin dealer.
H6	Compressor start up failure	<ul style="list-style-type: none"> Check that the compressor relay, compressor or PCB is not broken. Check that the supply voltage is not too low. Check that the refrigerant stop valves on the outdoor unit are open.
H8	CT failure	Contact your local Daikin dealer.
H9	Outdoor temperature thermistor failure (outdoor thermistor is broken)	Contact your local Daikin dealer.
J3	Discharge pipe thermistor failure	Contact your local Daikin dealer.
J6	Outdoor unit heat exchanger thermistor broken or disconnected	Contact your local Daikin dealer.
L3	Electric component failure	Contact your local Daikin dealer.
L4	Electric component failure	Contact your local Daikin dealer.
L5	Electric component failure	Contact your local Daikin dealer.
P4	Electric component failure	Contact your local Daikin dealer.
U0	Refrigerant failure (due to refrigerant leak)	Contact your local Daikin dealer.
U2	Main circuit voltage failure	Contact your local Daikin dealer.
U4	Communication error failure	Contact your local Daikin dealer.
U7	Communication error failure	Contact your local Daikin dealer.
UR	Communication error failure	Contact your local Daikin dealer.

TECHNICAL SPECIFICATIONS

General

	Heating/cooling models (EKHBX)	Heating only models (EKHBH)
Nominal capacity		
• cooling ^(a)		Refer to the Technical Data
• heating ^(b)		Refer to the Technical Data
Dimensions H x W x D	936 x 487 x 461	895 x 487 x 361
Weight		
• machine weight	65 kg	55 kg
• operation weight	80 kg	70 kg
Connections		
• water inlet/outlet	1" MBSP ^(c)	1" MBSP ^(c)
• water drain	hose nipple	hose nipple
• refrigerant liquid side	Ø6.4 mm (1/4 inch)	Ø6.4 mm (1/4 inch)
• refrigerant gas side	Ø15.9 mm (5/8 inch)	Ø15.9 mm (5/8 inch)
Expansion vessel		
• Volume	10 l	10 l
• Maximum working pressure (MWP)	3 bar	3 bar
Pump		
• Type	water cooled	water cooled
• no. of speed	3	3
Sound pressure level^(d)	27 dBA	27 dBA
Internal water volume	2 l	2 l
Pressure relief valve water circuit	3 bar	3 bar
Operation range - water side		
• heating	+30~+55°C	+30~+55°C
• cooling	+7~+20°C	-
Operation range - air side		
• heating	-20~+25°C	-20~+25°C
• cooling	+15~+43°C	-
• sanitary water by heat pump	-15~+35°C ^(e)	-15~+35°C ^(e)

- (a) Nominal cooling capacities are based on the following Eurovent conditions:
 evaporator: 12°C/7°C
 condenser: 30°C/35°C
- (b) Nominal heating capacities are based on the following Eurovent conditions:
 ambient: 7°C DB/6°C WB
 condenser: 30°C/35°C
- (c) MBSP = Male British Standard Pipe
- (d) At 1 m in front of the unit (free field condition)
- (e) Down to -20°C by booster heater and up to +43°C by booster heater

Electrical specifications

	Heating/cooling models (EKHBX)	Heating only models (EKHBH)
Standard unit (power supply via outdoor unit)		
• Power supply		230 V 50 Hz 1P
• Nominal running current		See outdoor unit installation manual
Backup heater		
• Power supply		See "Connection of the backup heater power supply" on page 14
• Maximum running current		See "Connection of the backup heater power supply" on page 14
Option sanitary water tank with booster heater		
• Power supply		See "Sanitary water tank specifications (optional)" on page 27
• Nominal running current		See "Sanitary water tank specifications (optional)" on page 27

Sanitary water tank specifications (optional)

	EKSWW150V3	EKSWW200V3	EKSWW200Z2	EKSWW300V3	EKSWW300Z2
Volume	150 l	200 l	200 l	300 l	300 l
Overall dimensions (Ø x H)	580 x 900 mm	580 x 1150 mm	580 x 1150 mm	580 x 1600 mm	580 x 1600 mm
Booster heater, power supply	230 V 50 Hz 1P	230 V 50 Hz 1P	400 V 50 Hz 2P	230 V 50 Hz 1P	400 V 50 Hz 2P
Booster heater, running current	13 A	13 A	7.5 A	13 A	7.5 A
Booster heater, capacity	3 kW	3 kW	3 kW	3 kW	3 kW
Connections	3/4" FBSP ^(a)	3/4" FBSP ^(a)	3/4" FBSP ^(a)	3/4" FBSP ^(a)	3/4" FBSP ^(a)
Weight (empty)	37 kg	45 kg	45 kg	59 kg	59 kg
Mounting	Wall or floor	Floor	Floor	Floor	Floor

- (a) FBSP = Female British Standard Pipe

NOTES

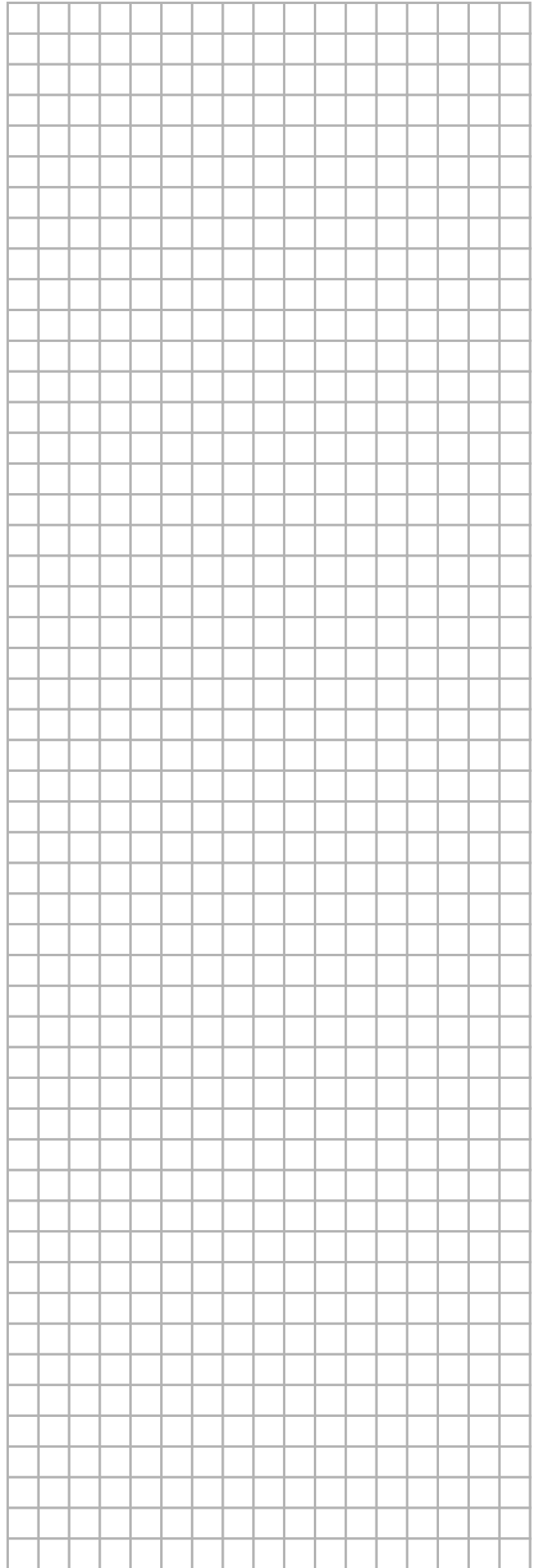

DAIKIN EUROPE NV

Zandvoordestraat 300, B-8400 Oostende, Belgium

4PW30818-1B